

Inhoudsopgave

Drijfwerkhuis 01	28
Elecktrisch 02	74
Handels & Kabels 00	64
Kappen 04	14
Koppeling 03	20
Motorkap 00	86
Schakelpoken 01	60
Stickers 01	78
Stuur & Kabels 02	58
Stuurboom 03	44
Tandwielen 01	30
Type Stickers 02	84
Wielas 00	34
Wielen & Banden 01	68
Parts Index	88

Code	Description	Notes
C01_0_27103	C01_00 - ENGINE PROTECTIONS	
C01_1_60543	C01_01 - ENGINE PROTECTIONS	
C01_2_60545	C01_02 - ENGINE PROTECTIONS	
C01_3_60548	C01_03 - ENGINE PROTECTIONS	
D01_0_27123	CLUTCH	
C.01.01.A0027_04	ENGINE PROTECTIONS	
D01_1_33518	CLUTCH	
D01_2_60564	CLUTCH	
D.01.02.A0027_03	CLUTCH	
E01_0_27146	GEARBOX	
F02_0_27212	GEARS	
E.01.01.A0027_01	GEARBOX	
F.02.02.A0027_01	GEARS	
G01_0_27251	WHEEL AXLE	
H02_0_27310	STEERING COLUMN	
H02_1_60701	STEERING COLUMN	
H.02.01.A0027_02	STEERING COLUMN	
H.02.01.A0027_03	STEERING COLUMN	
I02_0_27387	HANDLEBAR	
I02_1_45506	HANDLEBAR	
J02_0_27474	CONTROLS	
I.02.01.A0027_02	HANDLEBAR	
J.02.01.A0027_01	CONTROLS	
J.04.01.A0027_00	HANDLEBAR CONTROLS	
K01_0_27513	WHEELS	
K01_1_60913	WHEELS	
L01_0_27535	ELECTRIC STARTER	
L01_1_33613	ELECTRIC STARTER	
L01_2_60940	ELECTRIC STARTER	Version: 320 trendy, 330 trendy
M01_0_27555	STICKERS	
M01_1_60965	STICKERS	
M02_0_27566	STICKERS	
M02_1_60983	STICKERS	
M.02.02.A0027_02	STICKERS	

Code **Description**

Notes

S.01.01.A0027_00 S01_00 - ENGINE COVER KIT

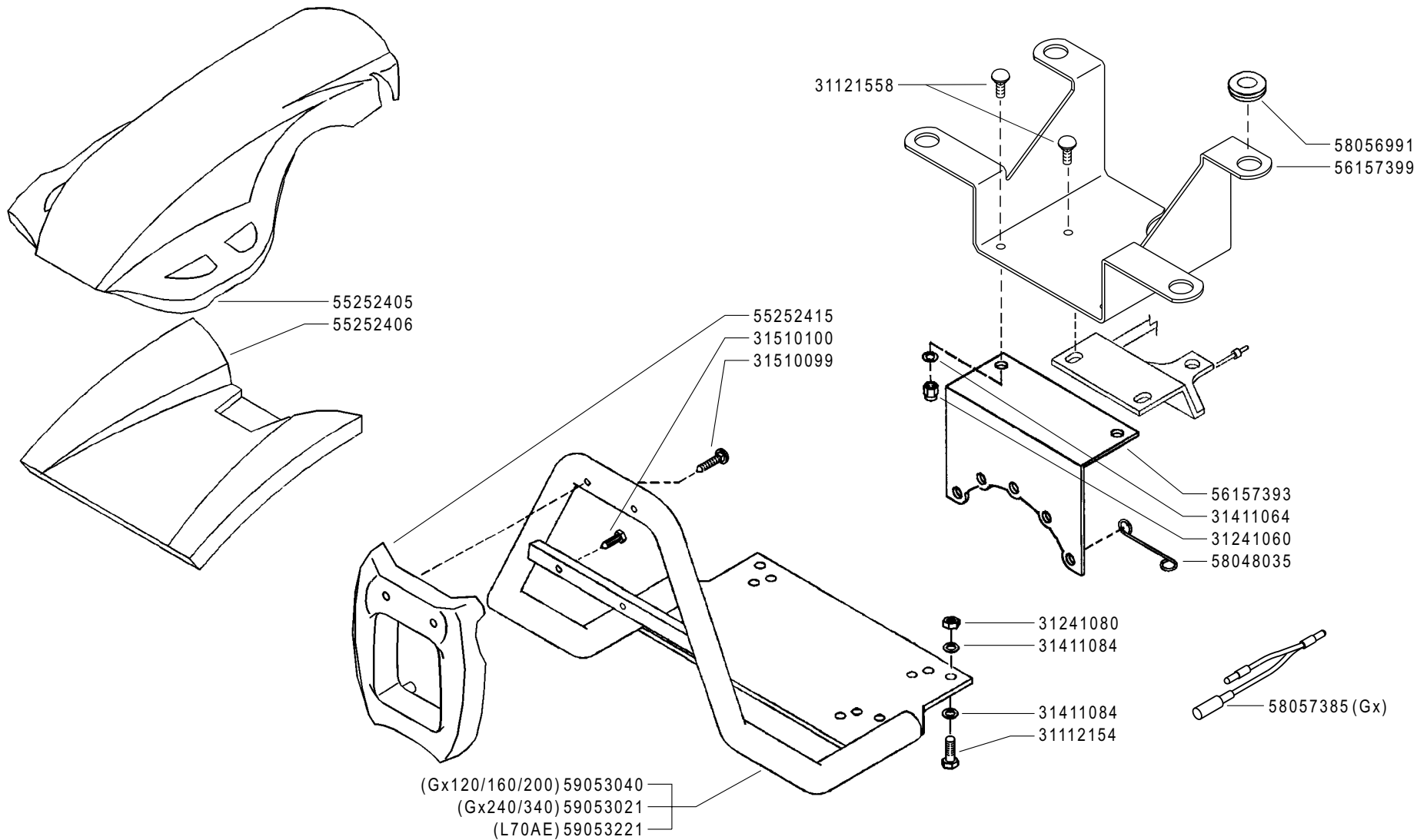

PROTEZIONI MOTORE

ENGINE PROTECTIONS
PROTECCIONES MOTOR

PROTECTIONS MOTEUR
MOTORSCHUTZ

DALLA MACCHINA
FROM THE MACHINE
DE LA MACHINE
DE LA MAQUINA
AB DER MASCHINE

N.

C01 0

11/2006

Rev.

ZENNE

FERRARI

300 TRENDY

Pos.	Code	Q.ty	Description	Notes
31112154	31112154	1	SCREW TE M8X40 UNI 5739 8G	
31121558	31121558	1	SCREW TTQ M6X16 UNI 5731	
31241060	31241060	1	HEXAGON SELFLOCK NUT M6	
31241080	31241080	1	HEXAGON SELFLOCK NUT M8	
31411064	31411064	1	WASHER 6,4x12,5	
31411084	31411084	1	WASHER 8,4x17	
31510099	31510099	1	RIBBED SCREW 6,3X38 UNI 6950	
31510100	31510100	1	RIBBED SCREW 6,3X19 UNI 6950	
55252405	55252405	1	GUARD	
55252406	55252406	1	GUARD	
55252415	55252415	1	GUARD	
56157393	56157393	1	HOLDER	
56157399	56157399	1	HOLDER	
58048035	58048035	1	HOLDER	
58056991	58056991	1	CABLE GLAND	
58057385	58057385	1	LINE	
59053021	59053021	1	COMPLETE BUMPERS	
59053040	59053040	1	COMPLETE BUMPERS	
59053221	59053221	1	COMPLETE BUMPERS	

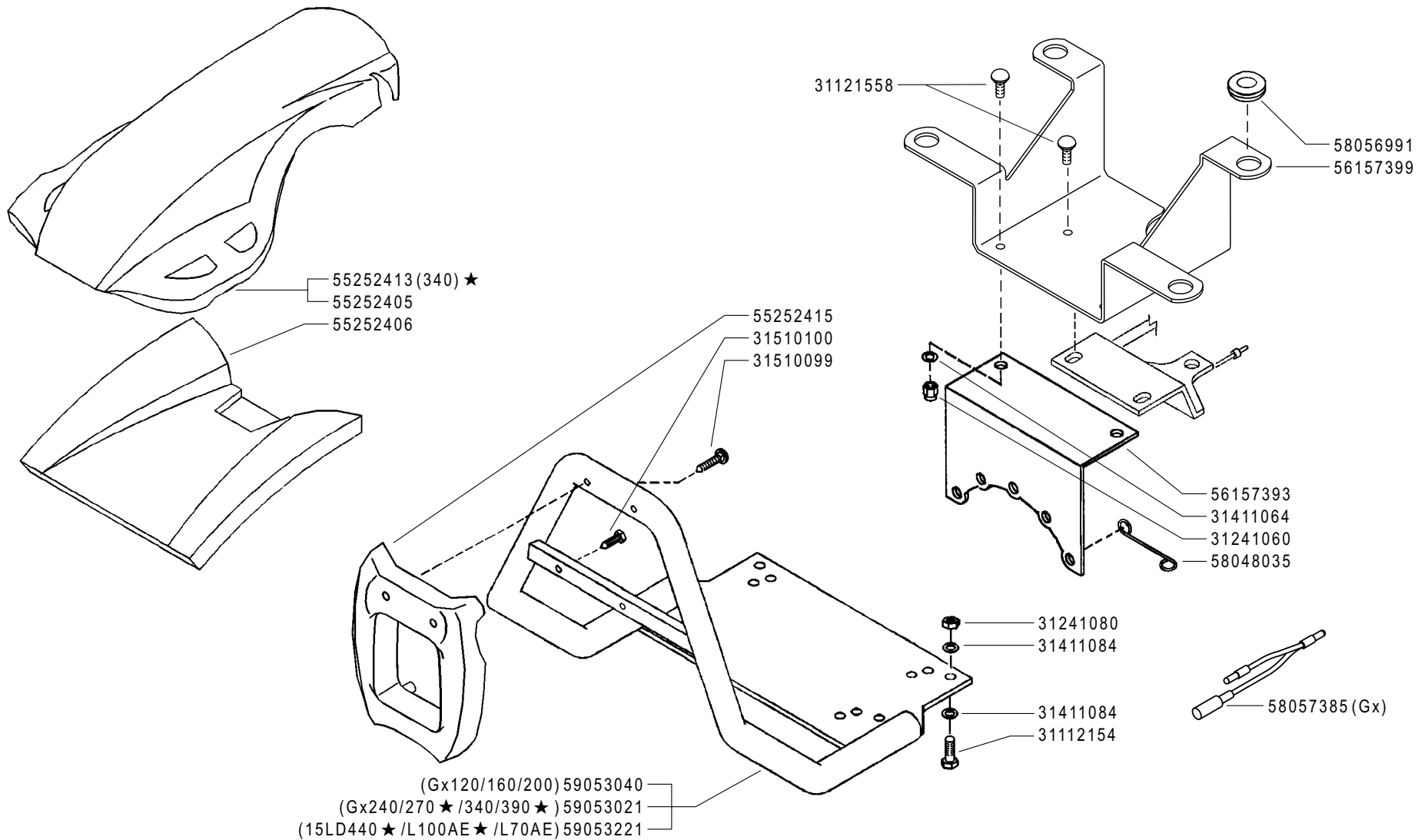

PROTEZIONI MOTORE

ENGINE PROTECTIONS
 PROTECCIONES MOTOR

PROTECTIONS MOTEUR
 MOTORSCHUTZ

DALLA MACCHINA
 FROM THE MACHINE
 DE LA MACHINE
 DE LA MAQUINA
 AB DER MASCHINE

★ N.

AGGIORNAMENTO
REVISION
MISE A JOUR
APLAZAMIENTO
ANPASSUNG

C01 1

10/2008

Rev.

ZENNE

FERRARI

300 TRENDY

Pos.	Code	Q.ty	Description	Notes
31112154	31112154	1	SCREW TE M8X40 UNI 5739 8G	
31121558	31121558	1	SCREW TTQ M6X16 UNI 5731	
31241060	31241060	1	HEXAGON SELFLOCK NUT M6	
31241080	31241080	1	HEXAGON SELFLOCK NUT M8	
31411064	31411064	1	WASHER 6,4x12,5	
31411084	31411084	1	WASHER 8,4x17	
31510099	31510099	1	RIBBED SCREW 6,3X38 UNI 6950	
31510100	31510100	1	RIBBED SCREW 6,3X19 UNI 6950	
55252405	55252405	1	GUARD	
55252406	55252406	1	GUARD	
55252413	55252413	1	GUARD	
55252415	55252415	1	GUARD	
56157393	56157393	1	HOLDER	
56157399	56157399	1	HOLDER	
58048035	58048035	1	HOLDER	
58056991	58056991	1	CABLE GLAND	
58057385	58057385	1	LINE	
59053021	59053021	1	COMPLETE BUMPERS	
59053040	59053040	1	COMPLETE BUMPERS	
59053221	59053221	1	COMPLETE BUMPERS	

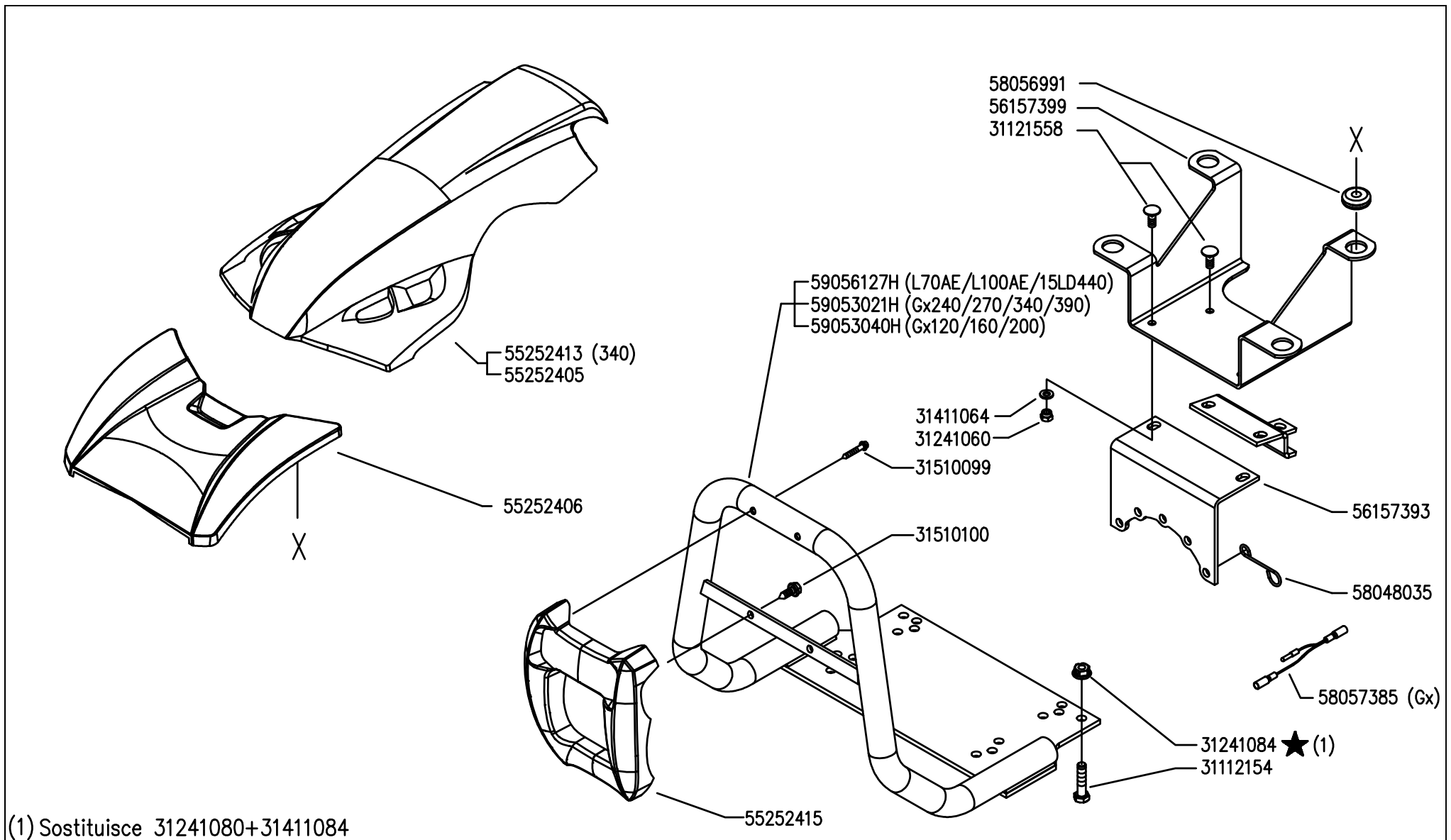

	300 TRENDY	PROTEZIONI MOTORE		DALLA MACCHINA DE LA MAQUINA DE LA MACHINA FROM THE MACHINE AB DER MASCHINE	AGGIORNAMENTO	C01	Rev. 2	
		ENGINE PROTECTIONS	PROTECTIONS MOTEUR		APLAZAMIENTO			
		PROTECCIONES MOTOR	MOTORSCHUTZ		MISE A JOUR			
					REVISION			
					ANPASSUNG			
				N.	06/2009			

Pos.	Code	Q.ty	Description	Notes
59053021	59053021H	1	BUMPER C.15LD-ACT-GX ALUM.	
59056127	59056127H	1	BUMPER FOR 740	
59053040	59053040H	1	ALU COMPLETE BUMPER GX160-200	
31112154	31112154	1	SCREW TE M8X40 UNI 5739 8G	
31121558	31121558	1	SCREW TTQ M6X16 UNI 5731	
31241060	31241060	1	HEXAGON SELFLOCK NUT M6	
31241084	31241084	1	SELFLOCK NUT M8 6S	
31411064	31411064	1	WASHER 6,4x12,5	
31510099	31510099	1	RIBBED SCREW 6,3X38 UNI 6950	
31510100	31510100	1	RIBBED SCREW 6,3X19 UNI 6950	
55252405	55252405	1	GUARD	
55252406	55252406	1	GUARD	
55252413	55252413	1	GUARD	
55252415	55252415	1	GUARD	
56157393	56157393	1	HOLDER	
56157399	56157399	1	HOLDER	
58048035	58048035	1	HOLDER	
58056991	58056991	1	CABLE GLAND	
58057385	58057385	1	LINE	

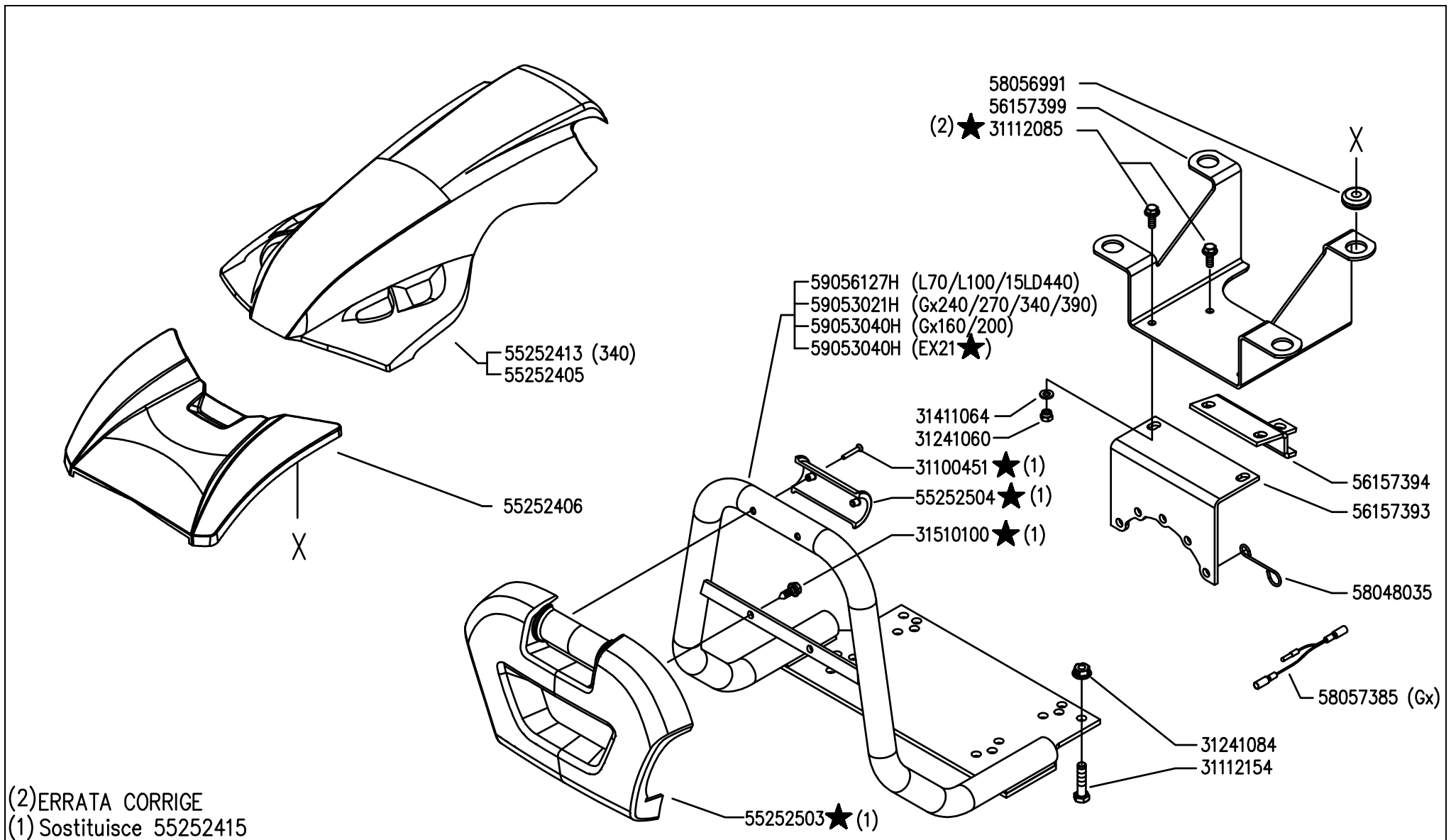

	300 TRENDY	PROTEZIONI MOTORE		DALLA MACCHINA DE LA MAQUINA DE LA MACHINA FROM THE MACHINE AB DER MASCHINE	N.	857706	Rev.
		ENGINE PROTECTIONS PROTECCIONES MOTOR	PROTECTIONS MOTEUR MOTORSCHUTZ				C01
						03/2011	

Pos.	Code	Q.ty	Description	Notes
31100451	31100451	1	SCREW 3,5X25	
31112085	31112085	1	SCREW TE M6X16 DIN 6921 8G	
31112154	31112154	1	SCREW TE M8X40 UNI 5739 8G	
31241060	31241060	1	HEXAGON SELFLOCK NUT M6	
31241084	31241084	1	SELFLOCK NUT M8 6S	
31411064	31411064	1	WASHER 6,4x12,5	
31510100	31510100	1	RIBBED SCREW 6,3X19 UNI 6950	
55252405	55252405	1	GUARD	
55252406	55252406	1	GUARD	
55252413	55252413	1	GUARD	
55252503	55252503	1	FREGIO ANT.MC 2010 FERRARI	
55252504	55252504	1	HALF BEARING	
56157393	56157393	1	HOLDER	
56157394	56157394	1	STOP	
56157399	56157399	1	HOLDER	
58048035	58048035	1	HOLDER	
58056991	58056991	1	CABLE GLAND	
58057385	58057385	1	LINE	
59053021	59053021H	1	BUMPER C.15LD-ACT-GX ALUM.	
59053040	59053040H	1	ALU COMPLETE BUMPER GX160-200	
59056127	59056127H	1	BUMPER FOR 740	

- (HONDA Gx120/160/200) (5/16x7/8) 31100003
- (HONDA Gx240/340) (3/8x1") 31100015
- HONDA Gx120/160/200) 31423084
- 31423105
- (HONDA Gx120/160/200) 53247488
- (HONDA Gx240/340) 53156150
- 37112231 (20x47x14) (HONDA Gx120/160/200)
- 37112233 (30x55x13) (HONDA Gx240/340)
- 56347484 (HONDA Gx240/340)
- 56356251 (HONDA Gx120/160/200)
- 31211080
- 31423084
- 31312088 (M8x40)

MOTORE ENGINE MOTEUR MOTOR	FRIZIONE EMBRAGUE EMBRAYAGE KUPPLUNG CLUTCH
Honda Gx120/160/200 (D=19)	59256275
Honda Gx240 (D=25,4)	59256279
Honda Gx340 (D=25,4)	59256280
Yanmar L70AE	59247884

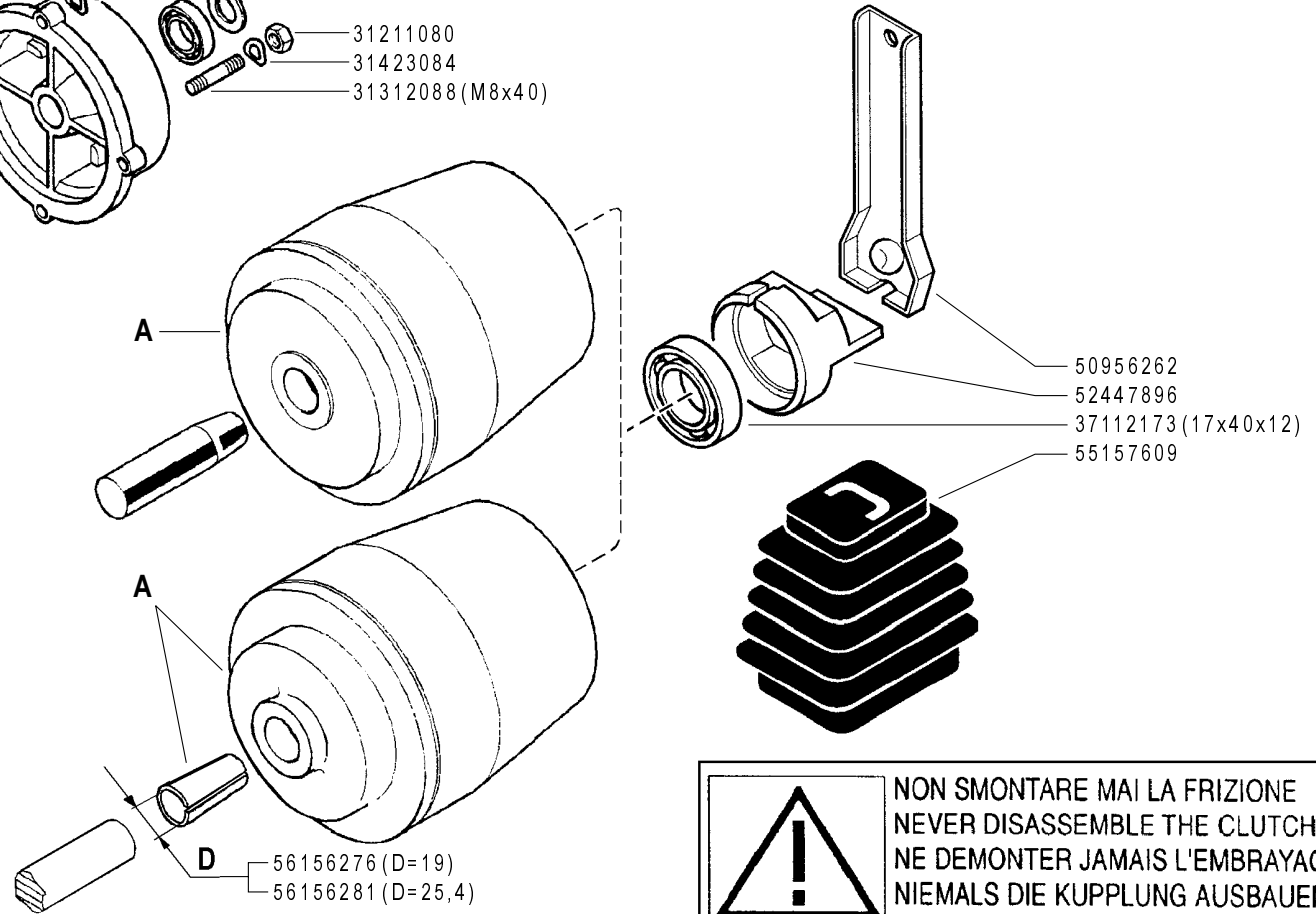

! NON SMONTARE MAI LA FRIZIONE
 NEVER DISASSEMBLE THE CLUTCH
 NE DEMONTER JAMAIS L'EMBRAYAGE
 NIEMALS DIE KUPPLUNG AUSBAUEN
 NO DESMONTAR JAMAS EL EMBRAGUE

FERRARI

300 TRENDY

FRIZIONE A CONO AUTOVENTILANTE

CLUTCH
EMBRAGUE

EMBRAYAGE
KUPPLUNG

DALLA MACCHINA
FROM THE MACHINE
DE LA MACHINE
DE LA MAQUINA
AB DER MASCHINE

N.

D01 0

11/2006

Rev.

ZENNE

Pos.	Code	Q.ty	Description	Notes
31100003	31100003	1	SCREW TE 5/16X7/8	
31100015	31100015	1	SCREW TE 3/8X1	
31211080	31211080	1	NUT M8	
31312088	31312088	1	STUD BOLT M8X40X14X14	
31423084	31423084	1	SPRING WASHER 8,4	
31423105	31423105	1	SPRING WASHER 10,5	
37112173	37112173	1	BEARING	
37112231	37112231	1	BEARING	
37112233	37112233	1	BEARING	
50956262	50956262	1	CLUTCH LEVER	
52447896	52447896	1	PRESSURE PLATE	
53156150	53156150	1	ENGINE FLANGE	
53247488	53247488	1	ENGINE FLANGE	
55157609	55157609	1	BELLOWS	
56156276	56156276	1	SLEEVE	
56156281	56156281	1	CENTRING BUSH	
56347484	56347484	1	SHIM	
56356251	56356251	1	SHIM D=19,6	
59247884	59247884	1	CLUTCH ASSY	
59256275	59256275	1	CLUTCH ASSY	
59256279	59256279	1	CLUTCH ASSY	
59256280	59256280	1	CLUTCH ASSY	

SERIAL

CLUTCH

CODE REV

D01_0_27123

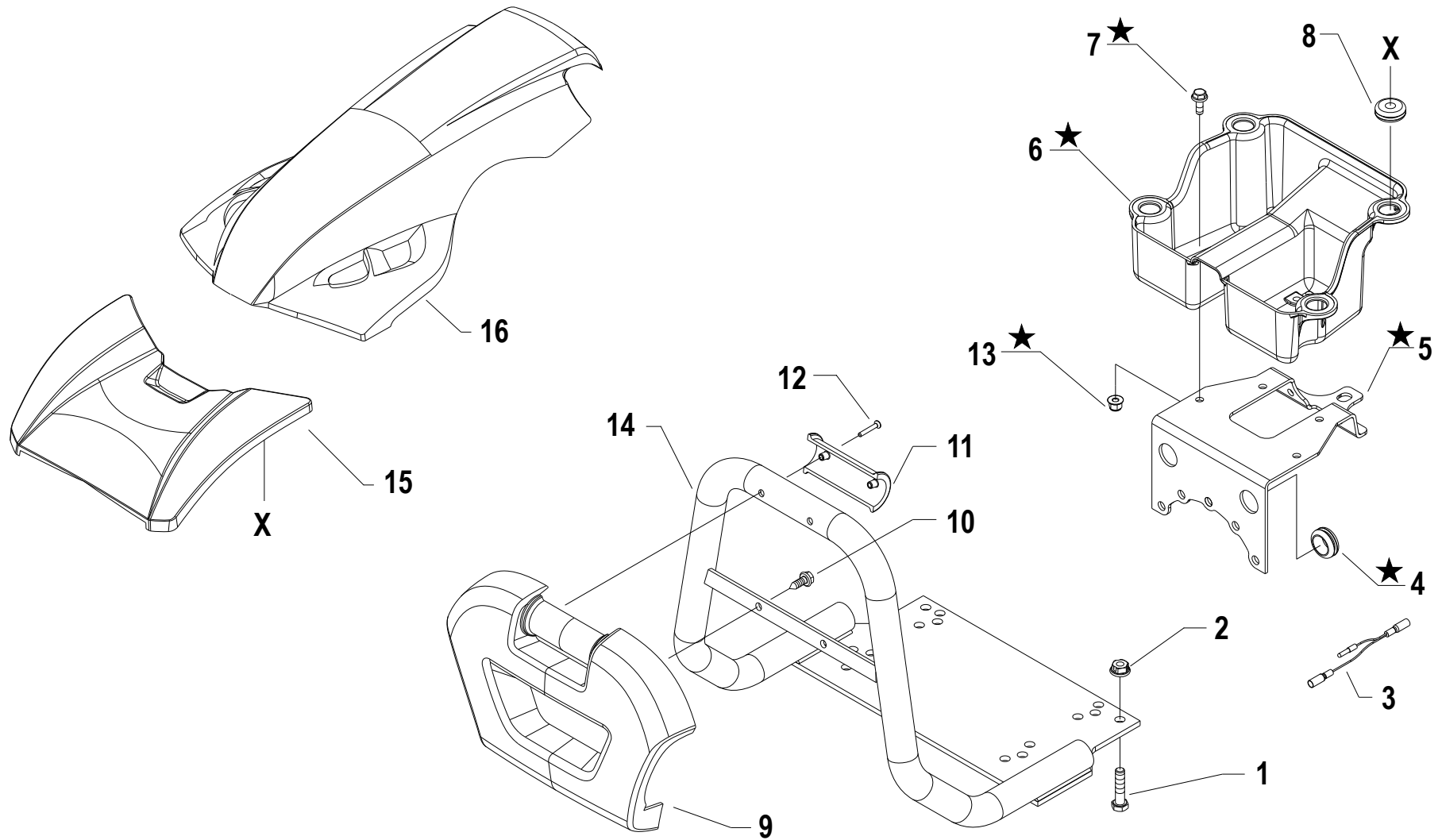

i = info - stop 2 sec. ★ = new part

Pos.	Code	Q.ty	Description	Notes
1	31112154		SCREW TE M8X40 UNI 5739 8G	
2	31241084		SELFLOCK NUT M8 6S	
3	58057385		LINE	
4	581C1004		CABLE GLAND	
5	561C1002		HOLDER	REPLACES 56157393
6	552C1001		COFANETTO SOST.CARENATURA	REPLACES 56157399
7	31112081		SCREW TE C/F M6X20 DIN 6921 8G	
8	58056991		CABLE GLAND	
9	55252503		FREGIO ANT.MC 2010 FERRARI	
10	31510100		RIBBED SCREW 6,3X19 UNI 6950	
11	55252504		HALF BEARING	
12	31100451		SCREW 3,5X25	
13	31241066		SELFLOCK M6 FL NY DIN 6926	REPLACES 31241060 + 31411064
14	59053021H		BUMPER C.15LD-ACT-GX ALUM.	GX240/GX270/GX340/GX390
14	59053040H		ALU COMPLETE BUMPER GX160-200	
14	59056127H		BUMPER FOR 740	L70/L100 - 15KD440
15	55252406		GUARD	
16	55252413		GUARD	340
16	55252405		GUARD	

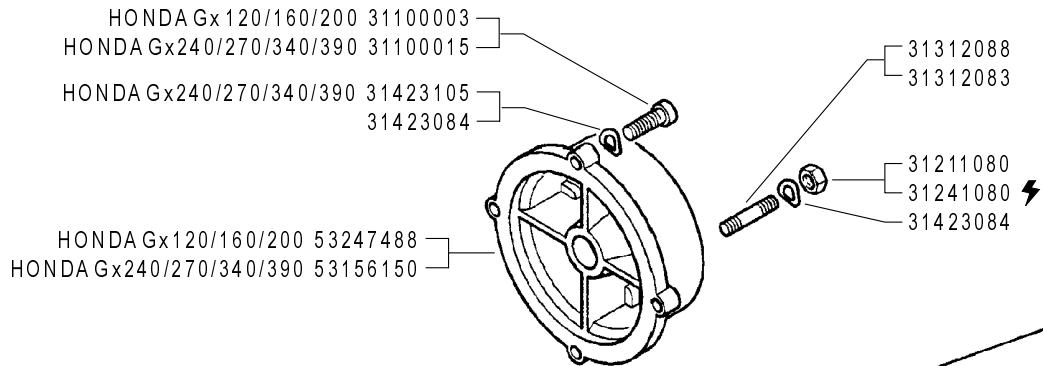

MOTORE ENGINE MOTEUR MOTOR MOTOR	FRIZIONE CLUTCH A EMBRAYAGE EMBRAGUE KUPPLUNG
Acme A220	59247884
Acme A220 (REF.)	59256255
Acme ACT280 - A349 - A360	59247884
Acme ACT340	59247971
Honda Gx390 - Gx340 D=25,4	59256280
Honda Gx240/270 D=25,4	59256279
Honda Gx120/160/200 D=19	59256275
Lombardini 15LD315/350	59247884
Lombardini 15LD500	59247924
Yanmar L100AE	59247971
Yanmar L70AE	59247884

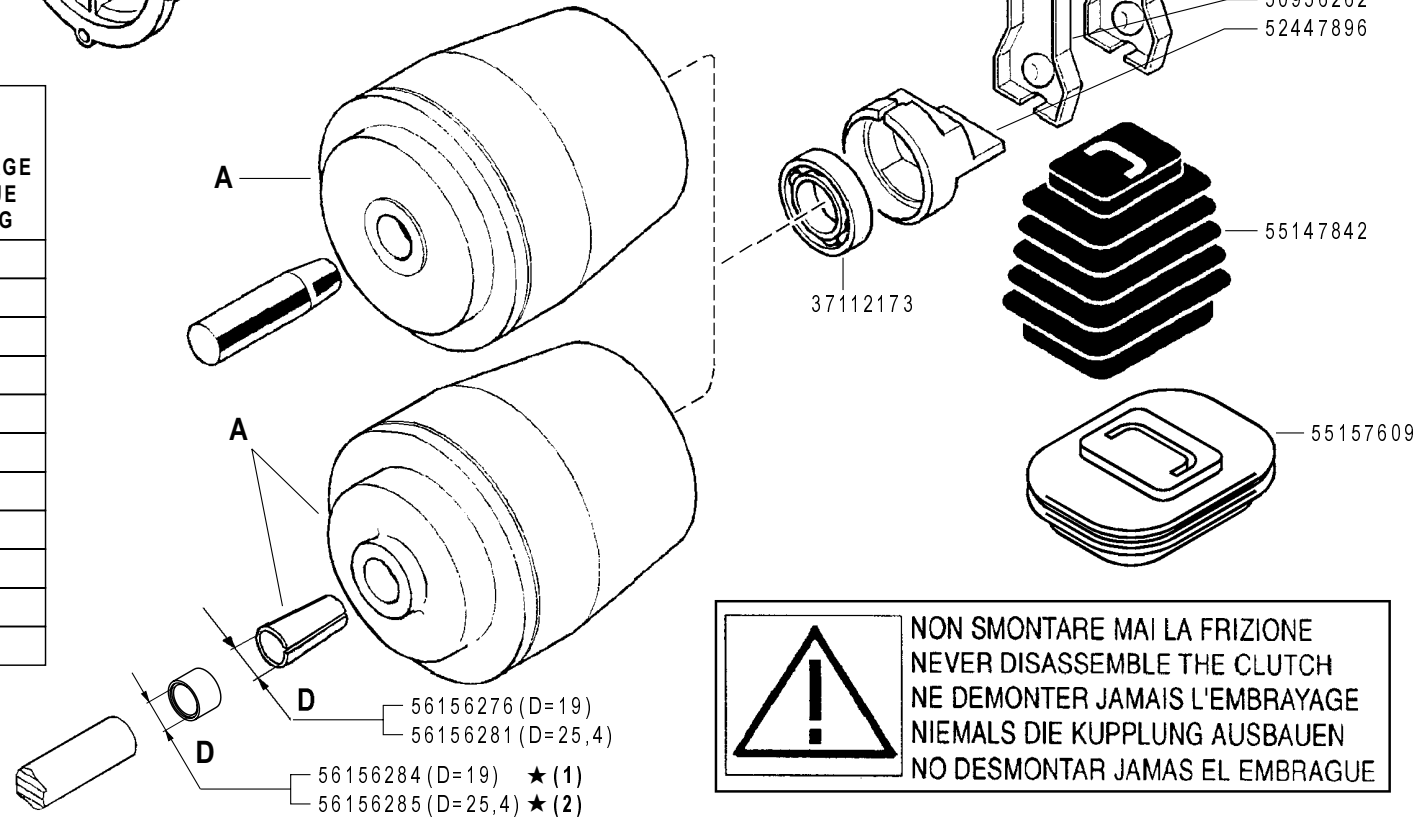

! NON SMONTARE MAI LA FRIZIONE
 NEVER DISASSEMBLE THE CLUTCH
 NE DEMONTER JAMAIS L'EMBRAYAGE
 NIEMALS DIE KUPPLUNG AUSBAUEN
 NO DESMONTAR JAMAS EL EMBRAGUE

FERRARI

300 TRENDY

FRIZIONE A CONO AUTOVENTILANTE

CLUTCH
EMBRAGUE

EMBAYAGE
KUPPLUNG

DALLA MACCHINA
FROM THE MACHINE
DE LA MACHINE
DE LA MAQUINA
AB DER MASCHINE

★ N.

(2) 779519
(1) 779324

D01 1

11/2006

Rev.

ZENNE

Pos.	Code	Q.ty	Description	Notes
31100003	31100003	1	SCREW TE 5/16X7/8	
31100015	31100015	1	SCREW TE 3/8X1	
31211080	31211080	1	NUT M8	
31241080	31241080	1	HEXAGON SELFLOCK NUT M8	
31312083	31312083	1	STUD BOLT M8X46X16X16	
31312088	31312088	1	STUD BOLT M8X40X14X14	
31423084	31423084	1	SPRING WASHER 8,4	
31423105	31423105	1	SPRING WASHER 10,5	
37112173	37112173	1	BEARING	
50956262	50956262	1	CLUTCH LEVER	
52447896	52447896	1	PRESSURE PLATE	
53156150	53156150	1	ENGINE FLANGE	
53247488	53247488	1	ENGINE FLANGE	
55147842	55147842	1	BELLOWS	
55157609	55157609	1	BELLOWS	
56147845	56147845	1	CLUTCH LEVER	
56156276	56156276	1	SLEEVE	
56156281	56156281	1	CENTRING BUSH	
56156284	56156284	1	SPACER	
56156285	56156285	1	SPACER	
59247884	59247884	1	CLUTCH ASSY	
59247924	59247924	1	CLUTCH	
59247971	59247971	1	CLUTCH	
59256255	59256255	1	CLUTCH ASSY	
59256275	59256275	1	CLUTCH ASSY	
59256279	59256279	1	CLUTCH ASSY	
59256280	59256280	1	CLUTCH ASSY	

SERIAL

CLUTCH

CODE REV

D01_1_33518

ROBIN EX 17 - HONDA Gx 120/160/200 31100003
 HONDA Gx 240/270/340/390 31100015
 HONDA Gx 240/270/340/390 31423105
 31423084

ROBIN EX 17 - HONDA Gx 120/160/200 53247488
 HONDA Gx 240/270/340/390 53156150

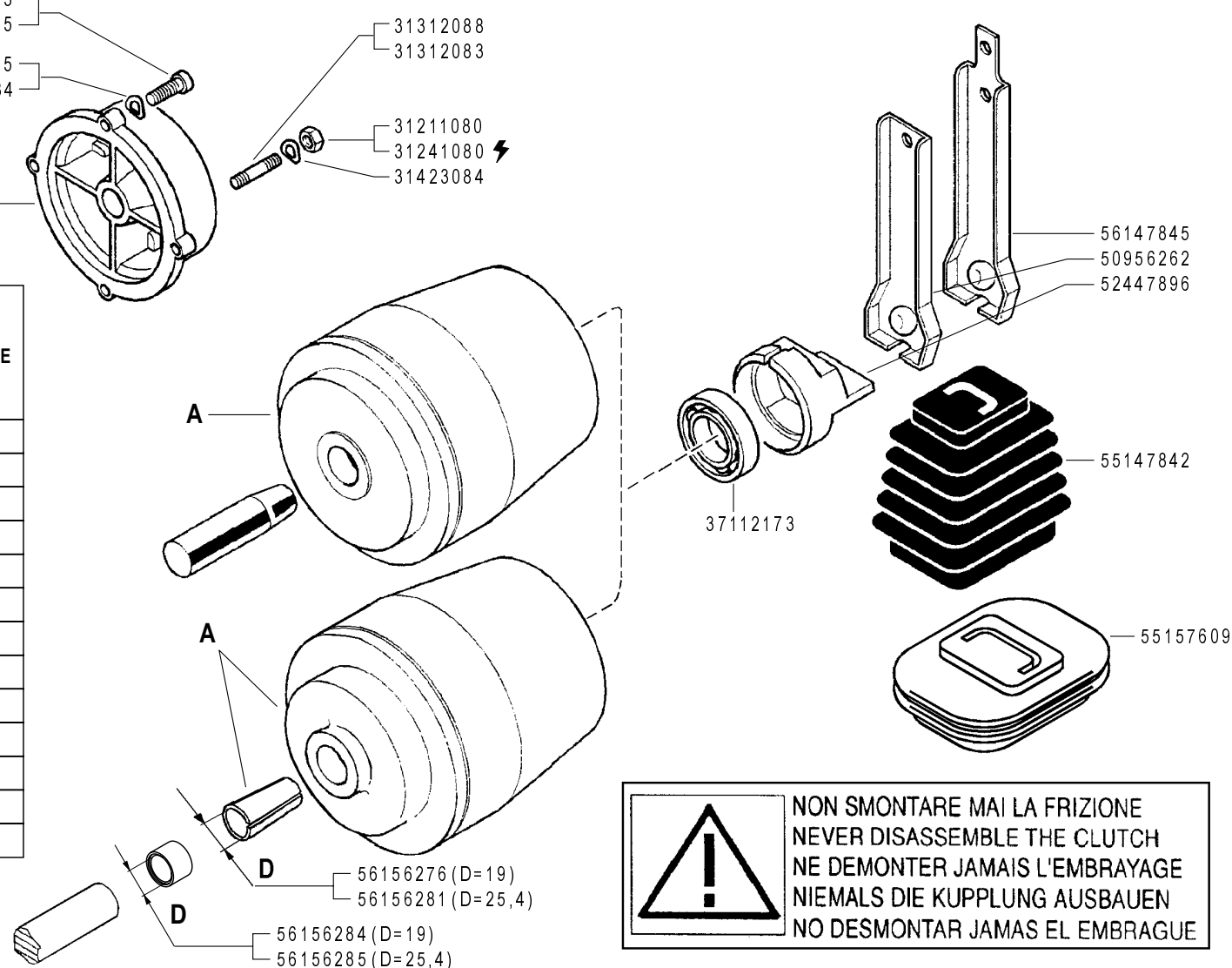

**! NON SMONTARE MAI LA FRIZIONE
 NEVER DISASSEMBLE THE CLUTCH
 NE DEMONTER JAMAIS L'EMBRAYAGE
 NIEMALS DIE KUPPLUNG AUSBAUEN
 NO DESMONTAR JAMAS EL EMBRAGUE**

MOTORE ENGINE MOTEUR MOTOR MOTOR	FRIZIONE CLUTCH A EMBRAYAGE EMBRAGUE KUPPLUNG
Acme A220	59247884
Acme A220 (REF.)	59256255
Acme ACT 280 - A349 - A360	59247884
Acme ACT 340	59247971
Honda Gx 390 - Gx 340 D=25,4	59256280
Honda Gx 240/270 D=25,4	59256279
Honda Gx 120/160/200 D=19	59256275
Lombardini 15LD315/350	59247884
Lombardini 15LD440 ★	59247971
Lombardini 15LD500	59247924
ROBIN EX 17 ★	59256275
Yanmar L100AE	59247971
Yanmar L70AE	59247884

FERRARI

300 TRENDY

FRIZIONE A CONO AUTOVENTILANTE

CLUTCH
EMBRAGUE

EMBRAYAGE
KUPPLUNG

DALLA MACCHINA
FROM THE MACHINE
DE LA MACHINE
DE LA MAQUINA
AB DER MASCHINE

★ N.

AGGIORNAMENTO

REVISION

MISE A JOUR

APLAZAMIENTO

ANPASSUNG

D01 2

10/2008

Rev.

ZENNE

Pos.	Code	Q.ty	Description	Notes
31100003	31100003	1	SCREW TE 5/16X7/8	
31100015	31100015	1	SCREW TE 3/8X1	
31211080	31211080	1	NUT M8	
31241080	31241080	1	HEXAGON SELFLOCK NUT M8	
31312083	31312083	1	STUD BOLT M8X46X16X16	
31312088	31312088	1	STUD BOLT M8X40X14X14	
31423084	31423084	1	SPRING WASHER 8,4	
31423105	31423105	1	SPRING WASHER 10,5	
37112173	37112173	1	BEARING	
50956262	50956262	1	CLUTCH LEVER	
52447896	52447896	1	PRESSURE PLATE	
53156150	53156150	1	ENGINE FLANGE	
53247488	53247488	1	ENGINE FLANGE	
55147842	55147842	1	BELLOWS	
55157609	55157609	1	BELLOWS	
56147845	56147845	1	CLUTCH LEVER	
56156276	56156276	1	SLEEVE	
56156281	56156281	1	CENTRING BUSH	
56156284	56156284	1	SPACER	
56156285	56156285	1	SPACER	
59247884	59247884	1	CLUTCH ASSY	
59247924	59247924	1	CLUTCH	
59247971	59247971	1	CLUTCH	
59256255	59256255	1	CLUTCH ASSY	
59256275	59256275	1	CLUTCH ASSY	
59256279	59256279	1	CLUTCH ASSY	
59256280	59256280	1	CLUTCH ASSY	

SERIAL

CLUTCH

CODE REV

D01_2_60564

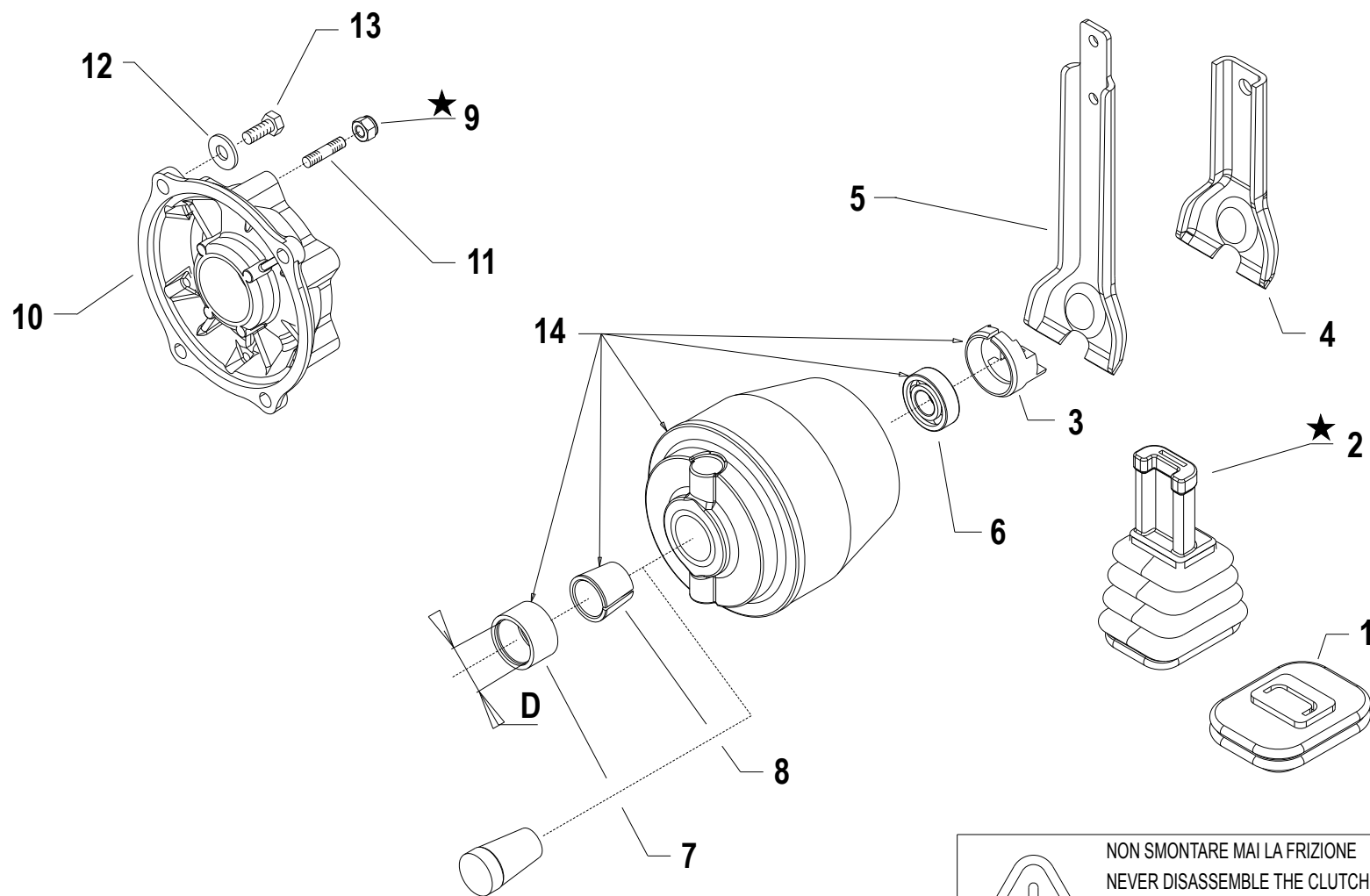

 NON SMONTARE MAI LA FRIZIONE
NEVER DISASSEMBLE THE CLUTCH
NE DEMONTER JAMAIS L'EMBRAYAGE
NIEMALS DIE KUPPLUNG AUSBAUEN
NO DESMONTAR JAMAS EL EMBRAGUE



i = info - stop 2 sec. ★ = new part

Pos.	Code	Q.ty	Description	Notes
1	55157609		BELLOWS	
2	55156481		BELLOWS	REPLACES 55147842
3	52447896		PRESSURE PLATE	
4	50956262		CLUTCH LEVER	
5	56147845		CLUTCH LEVER	
6	37112173		BEARING	
7	56156284		SPACER	
7	56156285		SPACER	
8	56156276		SLEEVE	
8	56156281		CENTRING BUSH	
9	31241080		HEXAGON SELFLOCK NUT M8	
9	31241083		SELFLOCK NUT M8	REPLACES 31211080 + 31423084
10	53156150		ENGINE FLANGE	GX240/GX270/GX340/GX390
10	53247488		ENGINE FLANGE	GX120/GX160/GX200 - EX17
11	31312083		STUD BOLT M8X46X16X16	
12	31423084		SPRING WASHER 8,4	
12	31423105		SPRING WASHER 10,5	GX240/GX270/GX340/GX390
13	31100003		SCREW TE 5/16X7/8	GX120/GX160/GX200
13	31100015		SCREW TE 3/8X1	GX240/GX270/GX340/GX390 - EX17
14	59247489		CONIC CLUTCH D=23 1 CPL SPRING	REPLACES 59247884 - 15LD315/15LD350 - L70AE - A220 -
14	59247513		CONIC CLUTCH D=24 2 SPRINGS	REPLACES 59247924 - 15LD500
14	59247823		CONIC CLUTCH D=23,2 2 SPRINGS	REPLACES 59247971 - L100AE - ACT340 - 15KD440
14	59256255		CLUTCH ASSY	A220 (REF.)
14	592C1010		CLUTCH D.19 Q(UP TO 9HP)	REPLACES 59256275 - GX120/GX160/GX200
14	592C1011		COMPLETE CLUTCH D=25,4 9HP	REPLACES 59256279 - GX240/GX270
14	592C1012		CONIC CLUTCH D=25,4 UP 9HP	REPLACES 59256280 - GX340/GX390

SERIAL
START
959257

CLUTCH

CODE REV

D.01.02.A0027_03

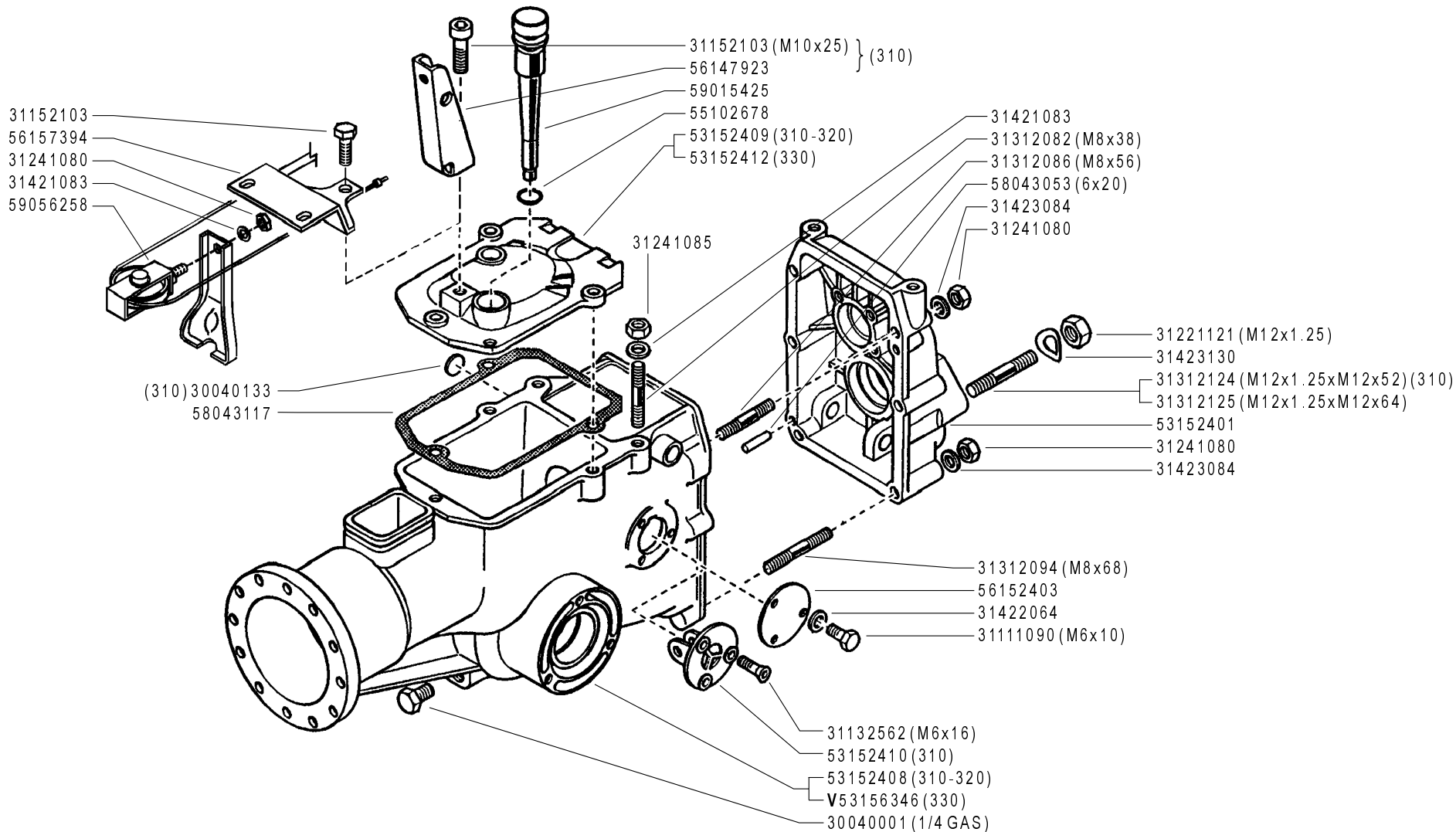

V = verde - green - vert - grün

FERRARI

300 TRENDY

SCATOLA CAMBIO

GEARBOX
CAJA DE CAMBIO

BOITE DE VITESSES
WECHSELGETRIEBE

DALLA MACCHINA
FROM THE MACHINE
DE LA MACHINE
DE LA MAQUINA
AB DER MASCHINE

N.

E01 0

11/2006

Rev.

ZENNE

Pos.	Code	Q.ty	Description	Notes
30040001	30040001	1	PLUG	
30040133	30040133	1	PLUG 22 DIN 470	
31111090	31111090	1	SCREW TE M5X10 UNI 5739 8G	
31132562	31132562	1	SCREW TSVEI M6X16 UNI 5933	
31152103	31152103	1	SCREW TCEI M10X25 UNI 5931	
31221121	31221121	1	NUT M12X1,25	
31241080	31241080	1	HEXAGON SELFLOCK NUT M8	
31241085	31241085	1	SELFLOCK NUT M8 6S	
31312082	31312082	1	STUD BOLT M8X38X14X20	
31312086	31312086	1	STUD BOLT M8X56X20X14	
31312094	31312094	1	STUD BOLT M8X68X14X36	
31312124	31312124	1	STUD BOLT	
31312125	31312125	1	STUD BOLT	
31421083	31421083	1	WASHER	
31422064	31422064	1	SPRING WASHER 6,4	
31423084	31423084	1	SPRING WASHER 8,4	
31423130	31423130	1	SPRING WASHER 13	
53152401	53152401	1	REAR COVER	
53152408	53152408	1	BODY	
53152409	53152409	1	COVER	
53152410	53152410	1	GEAR SUPPORT	
53152412	53152412	1	COVER	
53156346	53156346	1	BODY	
55102678	55102678	1	RUBBER RING	
56147923	56147923	1	BRACKET	
56152403	56152403	1	COVER	
56157394	56157394	1	STOP	
58043053	58043053	1	CYLINDRICAL PLUG	
58043117	58043117	1	COVER GASKET	
59015425	59015425	1	PLUG	
59056258	59056258	1	CLUTCH FORK	

SERIAL

GEARBOX

CODE REV

E01_0_27146

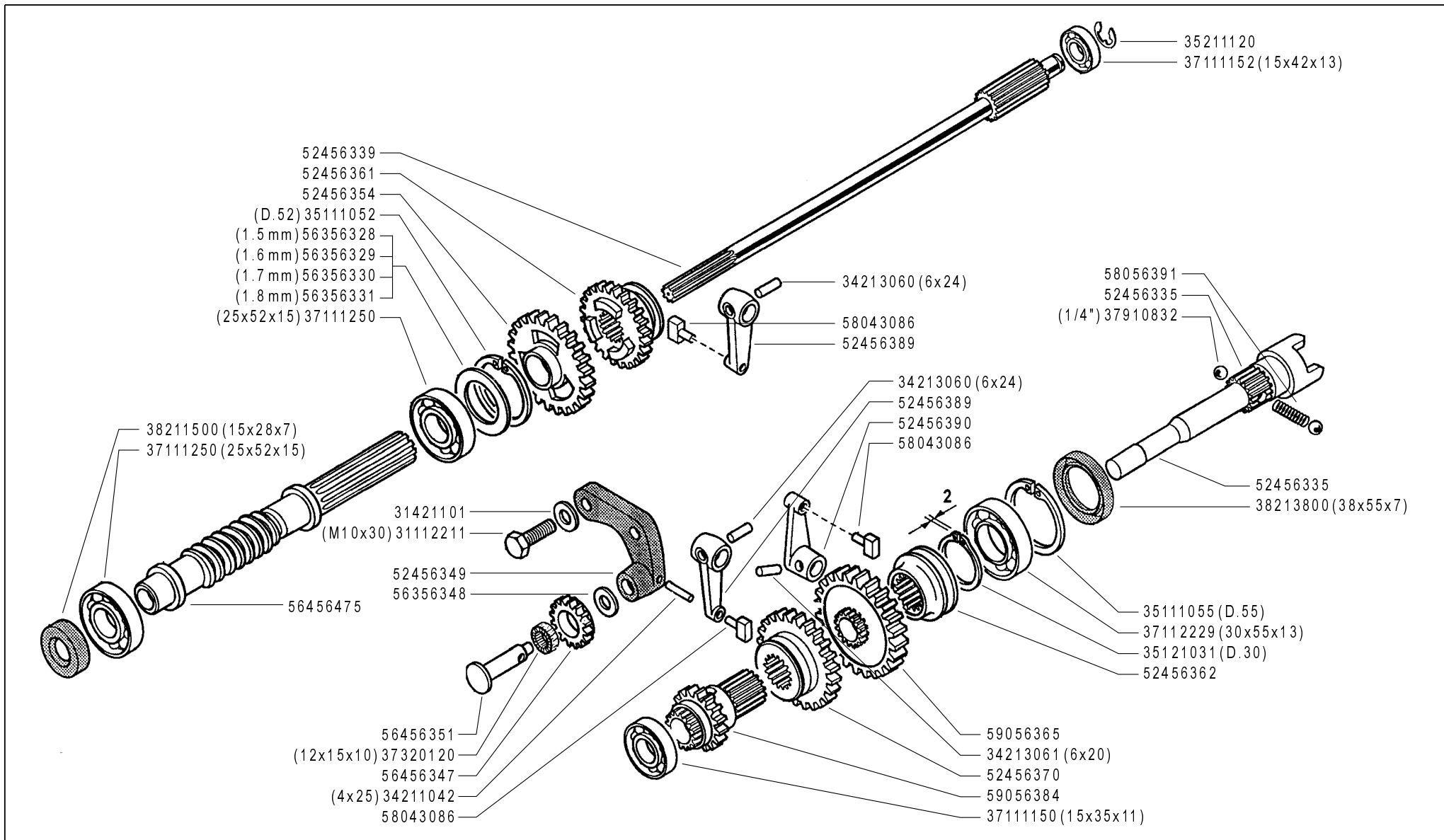

FERRARI

300 TRENDY

INGRANAGGI CAMBIO (320-330)

GEARS

ENGRANAJES

ENGRANAGES

ZÄHNRÄDER

DALLA MACCHINA
FROM THE MACHINE
DE LA MACHINE
DE LA MAQUINA
AB DER MASCHINE

N.

Rev.

F02 0

11/2006

ZENNE

Pos.	Code	Q.ty	Description	Notes
31112211	31112211	1	SCREW TE M10X30 UNI 5739	
31421101	31421101	1	WASHER	
34211042	34211042	1	ROLL PIN	
34213060	34213060	1	ROLL PIN	
34213061	34213061	1	ROLL PIN	
35111052	35111052	1	SEEGER RING	
35111055	35111055	1	SEEGER RING	
35121031	35121031	1	SEEGER RING	
35211120	35211120	1	SEEGER RING	
37111150	37111150	1	BEARING	
37111152	37111152	1	BEARING	
37111250	37111250	1	BEARING	
37112229	37112229	1	BEARING	
37320120	37320120	1	ROLLER CAGE 12X15/10	
37910832	37910832	1	BALL 1/4	
38211500	38211500	1	OIL SEAL 15X28X7	
38213800	38213800	1	OIL SEAL 38X55X7	
52456335	52456335	1	PTO SHAFT	
52456339	52456339	1	SHAFT	
52456349	52456349	1	GEAR SUPPORT	
52456354	52456354	1	GEAR	
52456361	52456361	1	SLIDER	
52456362	52456362	1	COUPLING	
52456370	52456370	1	SLIDER	
52456389	52456389	1	LEVER	
52456390	52456390	1	LEVER	
56356328	56356328	1	ADJUSTING RING SP=1,5	
56356329	56356329	1	ADJUSTING RING SP=1,6	
56356330	56356330	1	ADJUSTING RING SP=1,7	
56356331	56356331	1	ADJUSTING RING SP=1,8	
56356348	56356348	1	ADJUSTING RING	
56456347	56456347	1	GEAR	
56456351	56456351	1	GEAR PIN	
56456475	56456475	1	SCREW	

SERIAL

GEARS

CODE REV

F02_0_27212

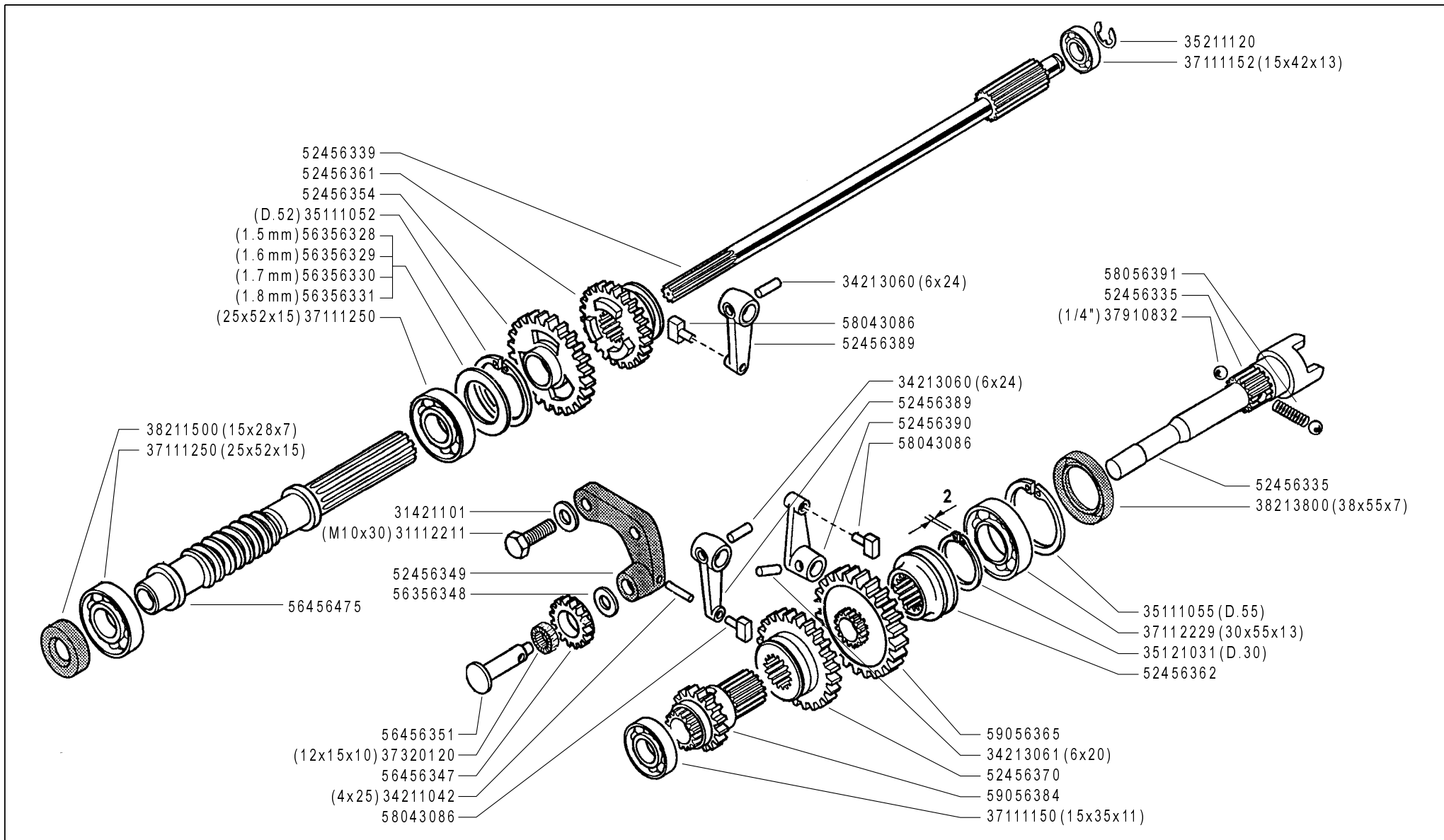

FERRARI

300 TRENDY

INGRANAGGI CAMBIO (320-330)

GEARS

ENGRANAJES

ENGRANAGES

ZÄHNRÄDER

DALLA MACCHINA
 FROM THE MACHINE
 DE LA MACHINE
 DE LA MAQUINA
 AB DER MASCHINE

N.

F02 0

11/2006

Rev.

ZENNE

Pos.	Code	Q.ty	Description	Notes
58043086	58043086	1	SHOE	
58056391	58056391	1	SPRING	
59056365	59056365	1	PTO GEAR	
59056384	59056384	1	DOUBLE GEAR	

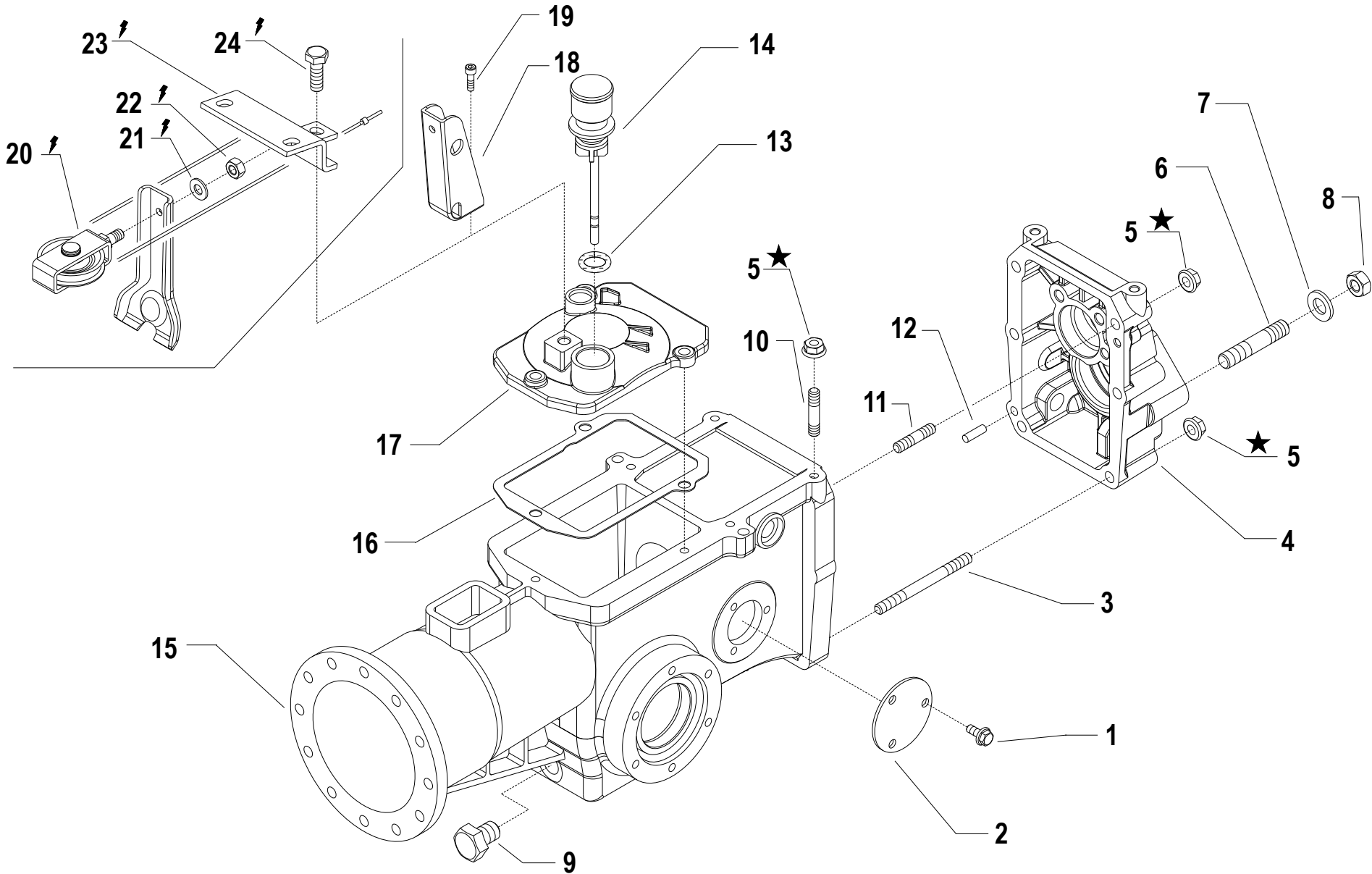

i = info - stop 2 sec. ★ = new part

Pos.	Code	Q.ty	Description	Notes
1	31112083		SCREW M6X12	
2	56147520Z		COVER	
3	31312094		STUD BOLT M8X68X14X36	
4	53156332V		REAR COVER	
5	31241084		SELFLOCK NUT M8 6S	
6	31312124		STUD BOLT	310
6	31312125		STUD BOLT	
7	31423130		SPRING WASHER 13	
8	31221121		NUT M12X1,25	
9	30040001		PLUG	
10	31312082		STUD BOLT M8X38X14X20	
11	31312086		STUD BOLT M8X56X20X14	
12	58043053		CYLINDRICAL PLUG	
13	55102678		RUBBER RING	
14	59015425		PLUG	
15	53156346V		BODY	
16	58043117		COVER GASKET	
17	53143128V		COVER	
17	53143875V		GEARBOX HOUSING COVER	330
18	56147923N		BRACKET	
19	31152103		SCREW TCEI M10X25 UNI 5931	
20	59056258		CLUTCH FORK	
21	31421083		WASHER	
22	31241080		HEXAGON SELFLOCK NUT M8	
23	56157394N		STOP	
24	31152103		SCREW TCEI M10X25 UNI 5931	

SERIAL
START
963640

GEARBOX

CODE REV

E.01.01.A0027_01

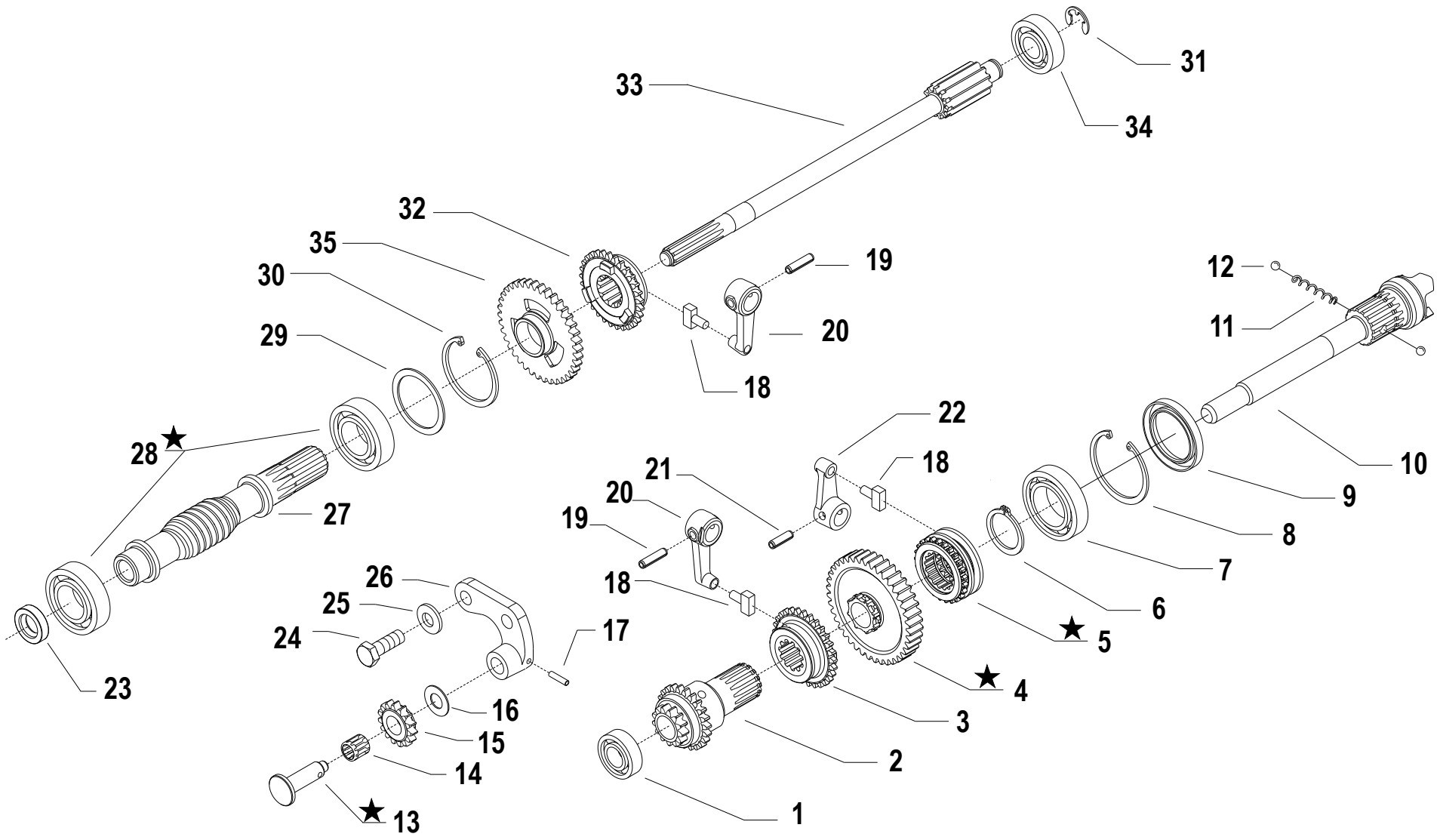

i = info - stop 2 sec. ★ = new part

Pos.	Code	Q.ty	Description	Notes
1	37111150		BEARING	
2	59056384		DOUBLE GEAR	
3	52456370		SLIDER	
4	59056707		PTO GEAR	Replaces 59056365 + 52456362
5	52456706		PTO COUPLING	Replaces 59056365 + 52456362
6	35121031		SEEGER RING	
7	37112229		BEARING	
8	35111055		SEEGER RING	
9	38213800		OIL SEAL 38X55X7	
10	52456335		PTO SHAFT	
11	58056391		SPRING	
12	37910832		BALL 1/4	
13	56456736		GEAR PIN	Replaces 56456351
14	37320120		ROLLER CAGE 12X15/10	
15	56456347		GEAR	
16	56356348		ADJUSTING RING	
17	34211042		ROLL PIN	
18	58043086		SHOE	
19	34213060		ROLL PIN	
20	52456389		LEVER	
21	34213061		ROLL PIN	
22	52456390		LEVER	
23	38211500		OIL SEAL 15X28X7	
24	31112211		SCREW TE M10X30 UNI 5739	
25	31421101		WASHER	
26	52456349		GEAR SUPPORT	
27	56456475		SCREW	
28	37111255		BEARING	
29	56356328		ADJUSTING RING SP=1,5	
29	56356329		ADJUSTING RING SP=1,6	
29	56356330		ADJUSTING RING SP=1,7	
29	56356331		ADJUSTING RING SP=1,8	
30	35111052		SEEGER RING	
31	35211120		SEEGER RING	

SERIAL
START
937702

GEARS

CODE REV

F.02.02.A0027_01

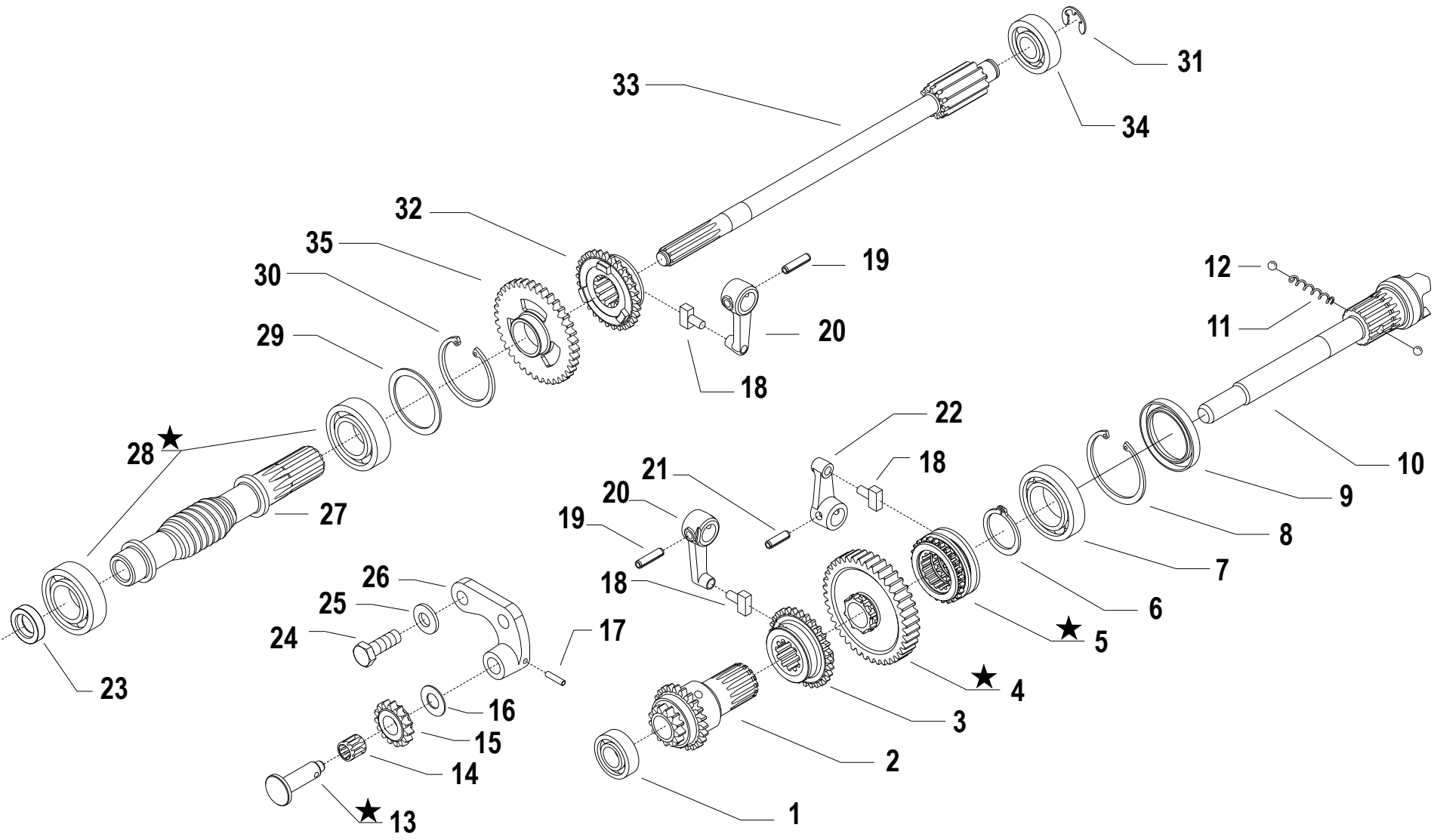

i = info - stop 2 sec. ★ = new part

Pos.	Code	Q.ty	Description	Notes
32	52456361		SLIDER	
33	52456339		SHAFT	
34	37111152		BEARING	
35	52456354		GEAR	

SERIAL
START
937702

GEARS

CODE REV
F.02.02.A0027_01

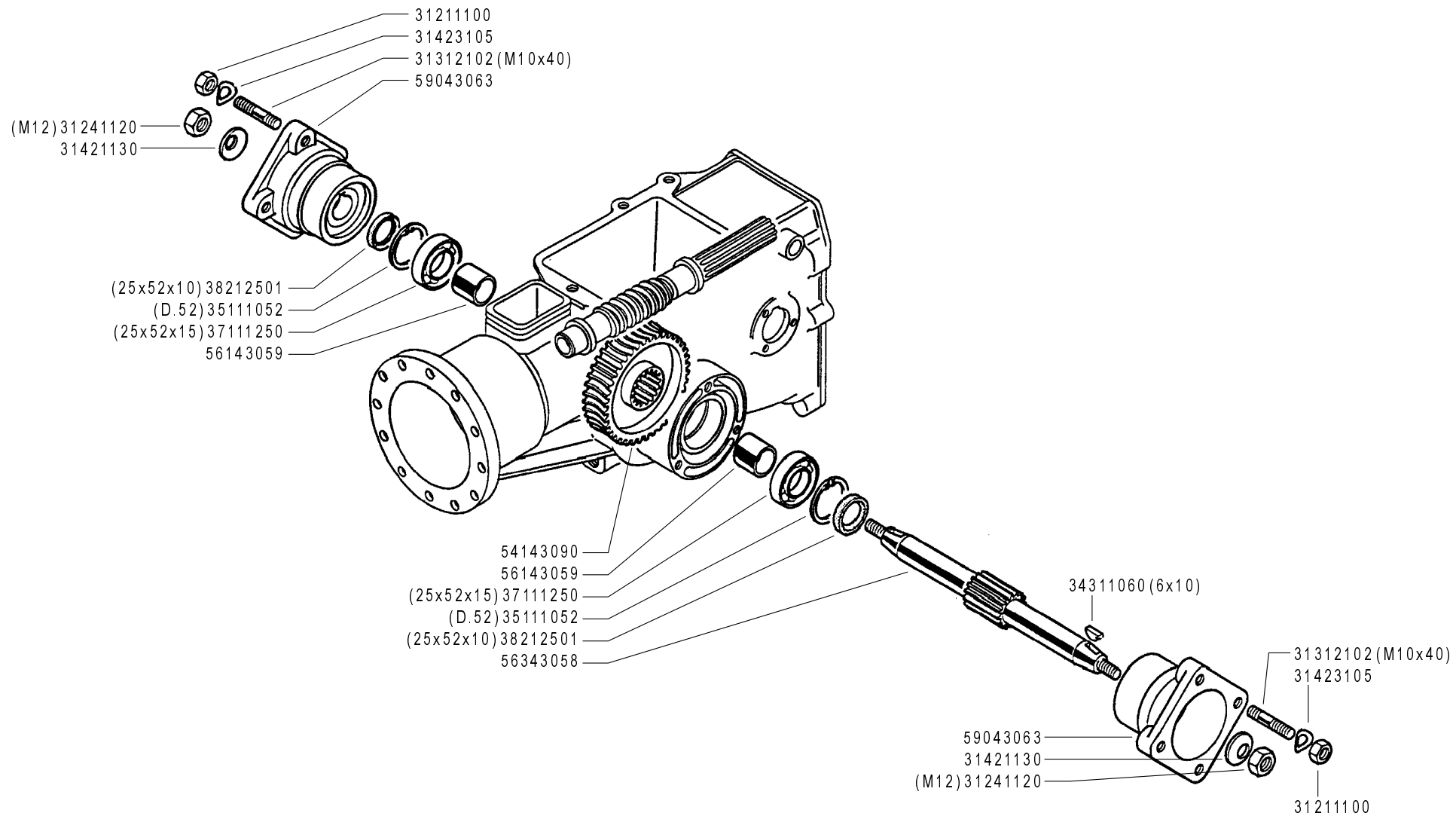

ASSE RUOTE (310-320)

WHEEL AXLE
 EJE RUEDAS

ESSIEU ROUES
 RÄDACHSE

DALLA MACCHINA
 FROM THE MACHINE
 DE LA MACHINE
 DE LA MAQUINA
 AB DER MASCHINE

N.

G01 0

11/2006

Rev.

ZENNE



300 TRENDY

Pos.	Code	Q.ty	Description	Notes
31211100	31211100	1	NUT M10	
31241120	31241120	1	SELFLOCK NUT M12	
31312102	31312102	1	STUD BOLT M10X40X24X12	
31421130	31421130	1	WASHER	
31423105	31423105	1	SPRING WASHER 10,5	
34311060	34311060	1	KEY 6X10 UNI 6606	
35111052	35111052	1	SEEGER RING	
37111250	37111250	1	BEARING	
38212501	38212501	1	OIL SEAL 25X52X10	
54143090	54143090	1	CROWN WHEEL	
56143059	56143059	1	SPACER	
56343058	56343058	1	AXLE SHAFT	
59043063	59043063	1	WHEEL HUB	

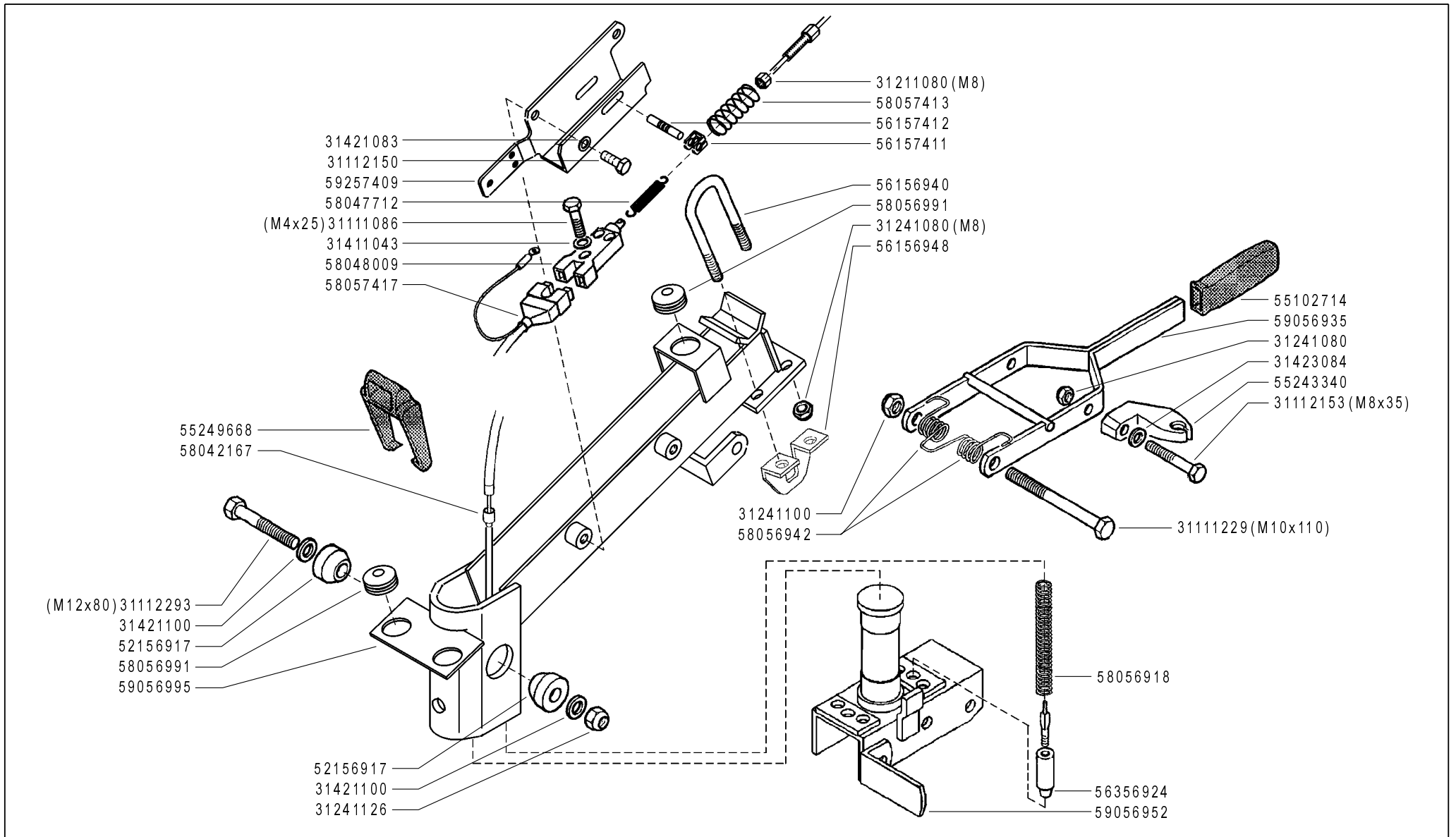

FERRARI

300 TRENDY

PIANTONE (320-330)

STEERING COLUMN
COLUMNNA

PLANTON
LENKSÄULE

DALLA MACCHINA
FROM THE MACHINE
DE LA MACHINE
DE LA MAQUINA
AB DER MASCHINE

N.

H02 0

11/2006

Rev.

ZENNE

Pos.	Code	Q.ty	Description	Notes
31111086	31111086	1	SCREW TE M4X25 UNI 5739 8G	
31111229	31111229	1	SCREW TE M10X110 UNI 5737 8G	
31112150	31112150	1	SCREW TE M8X20 UNI 5739 8G	
31112153	31112153	1	SCREW TE M8X35 UNI 5739 8G	
31112293	31112293	1	SCREW TE M12X80 UNI 5737	
31211080	31211080	1	NUT M8	
31241080	31241080	1	HEXAGON SELFLOCK NUT M8	
31241100	31241100	1	SELFLOCK HEXAGON NUT M10	
31241126	31241126	1	SELFLOCK NUT M12	
31411043	31411043	1	WASHER 4,3X9	
31421083	31421083	1	WASHER	
31421100	31421100	1	CUP SPRING	
31423084	31423084	1	SPRING WASHER 8,4	
52156917	52156917	1	WEDGE	
55102714	55102714	1	KNOB	
55243340	55243340	1	SUPPORT	
55249668	55249668	1	PASSING	
56156940	56156940	1	U BOLT	
56156948	56156948	1	STOP	
56157411	56157411	1	FORK	
56157412	56157412	1	PIN	
56356924	56356924	1	FERRULE	
58042167	58042167	1	SHEATH TERMINAL	
58047712	58047712	1	SPRING	
58048009	58048009	1	SWITCH	
58056918	58056918	1	SPRING	
58056942	58056942	1	SPRING	
58056991	58056991	1	CABLE GLAND	
58057413	58057413	1	RETAINING SPRING	
58057417	58057417	1	WIRING	
59056935	59056935	1	LEVER	
59056952	59056952	1	SUPPORT	
59056995	59056995	1	COLUMN	
59257409	59257409	1	SUPPORT	

SERIAL

STEERING COLUMN

CODE REV

H02_0_27310

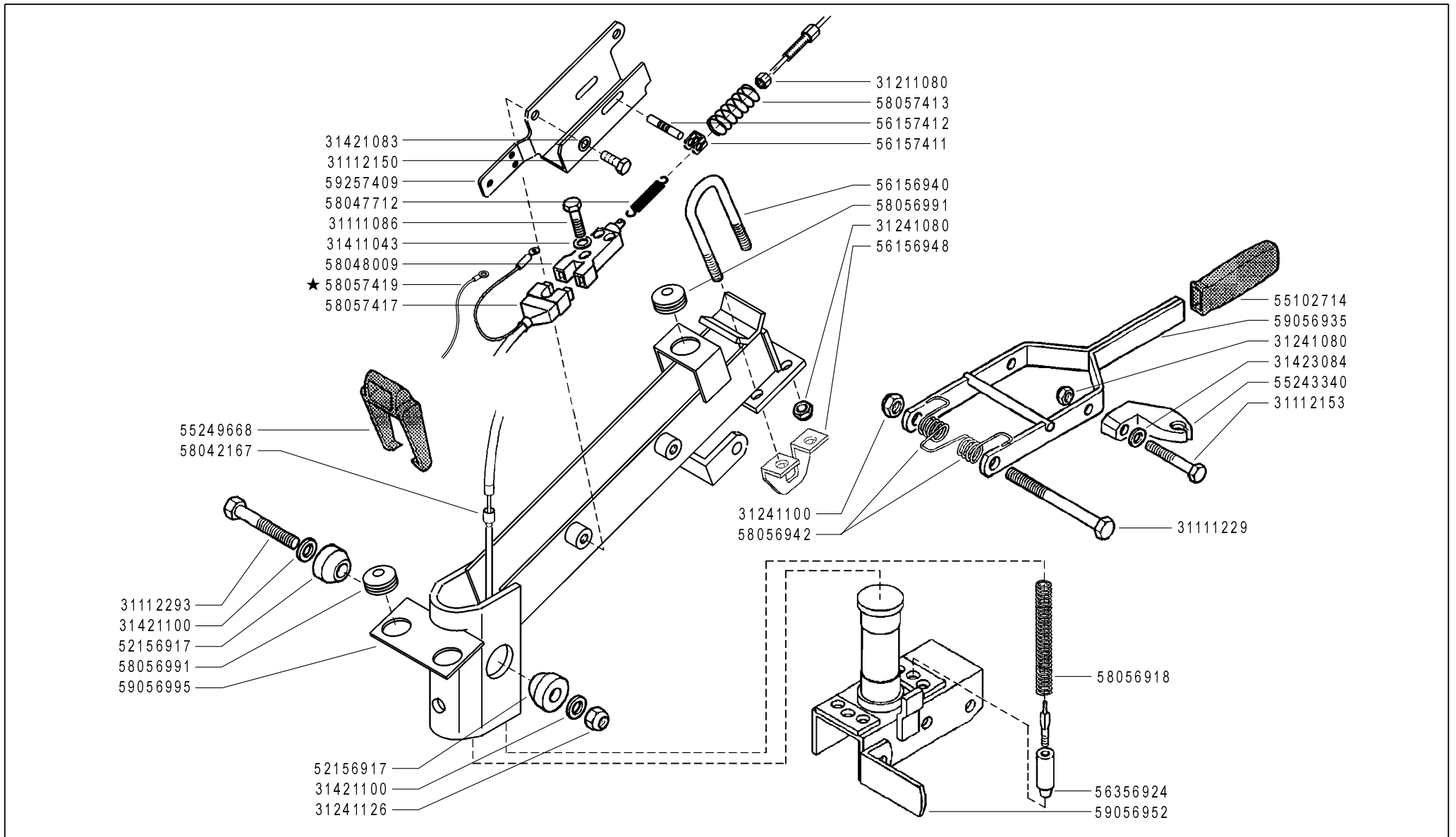

FERRARI

300 TRENDY

PIANTONE (320-330)

STEERING COLUMN
COLUMNNA

PLANTON
LENKSÄULE

DALLA MACCHINA
FROM THE MACHINE
DE LA MACHINE
DE LA MAQUINA
AB DER MASCHINE

★ N.

794196

H02 1

06/2007

Rev.

ZENNE

Pos.	Code	Q.ty	Description	Notes
31111086	31111086	1	SCREW TE M4X25 UNI 5739 8G	
31111229	31111229	1	SCREW TE M10X110 UNI 5737 8G	
31112150	31112150	1	SCREW TE M8X20 UNI 5739 8G	
31112153	31112153	1	SCREW TE M8X35 UNI 5739 8G	
31112293	31112293	1	SCREW TE M12X80 UNI 5737	
31211080	31211080	1	NUT M8	
31241080	31241080	1	HEXAGON SELFLOCK NUT M8	
31241100	31241100	1	SELFLOCK HEXAGON NUT M10	
31241126	31241126	1	SELFLOCK NUT M12	
31411043	31411043	1	WASHER 4,3X9	
31421083	31421083	1	WASHER	
31421100	31421100	1	CUP SPRING	
31423084	31423084	1	SPRING WASHER 8,4	
52156917	52156917	1	WEDGE	
55102714	55102714	1	KNOB	
55243340	55243340	1	SUPPORT	
55249668	55249668	1	PASSING	
56156940	56156940	1	U BOLT	
56156948	56156948	1	STOP	
56157411	56157411	1	FORK	
56157412	56157412	1	PIN	
56356924	56356924	1	FERRULE	
58042167	58042167	1	SHEATH TERMINAL	
58047712	58047712	1	SPRING	
58048009	58048009	1	SWITCH	
58056918	58056918	1	SPRING	
58056942	58056942	1	SPRING	
58056991	58056991	1	CABLE GLAND	
58057413	58057413	1	RETAINING SPRING	
58057417	58057417	1	WIRING	
58057419	58057419	1	WIRING	
59056935	59056935	1	LEVER	
59056952	59056952	1	SUPPORT	
59056995	59056995	1	COLUMN	

SERIAL
START
794196

STEERING COLUMN

CODE REV
H02_1_60701

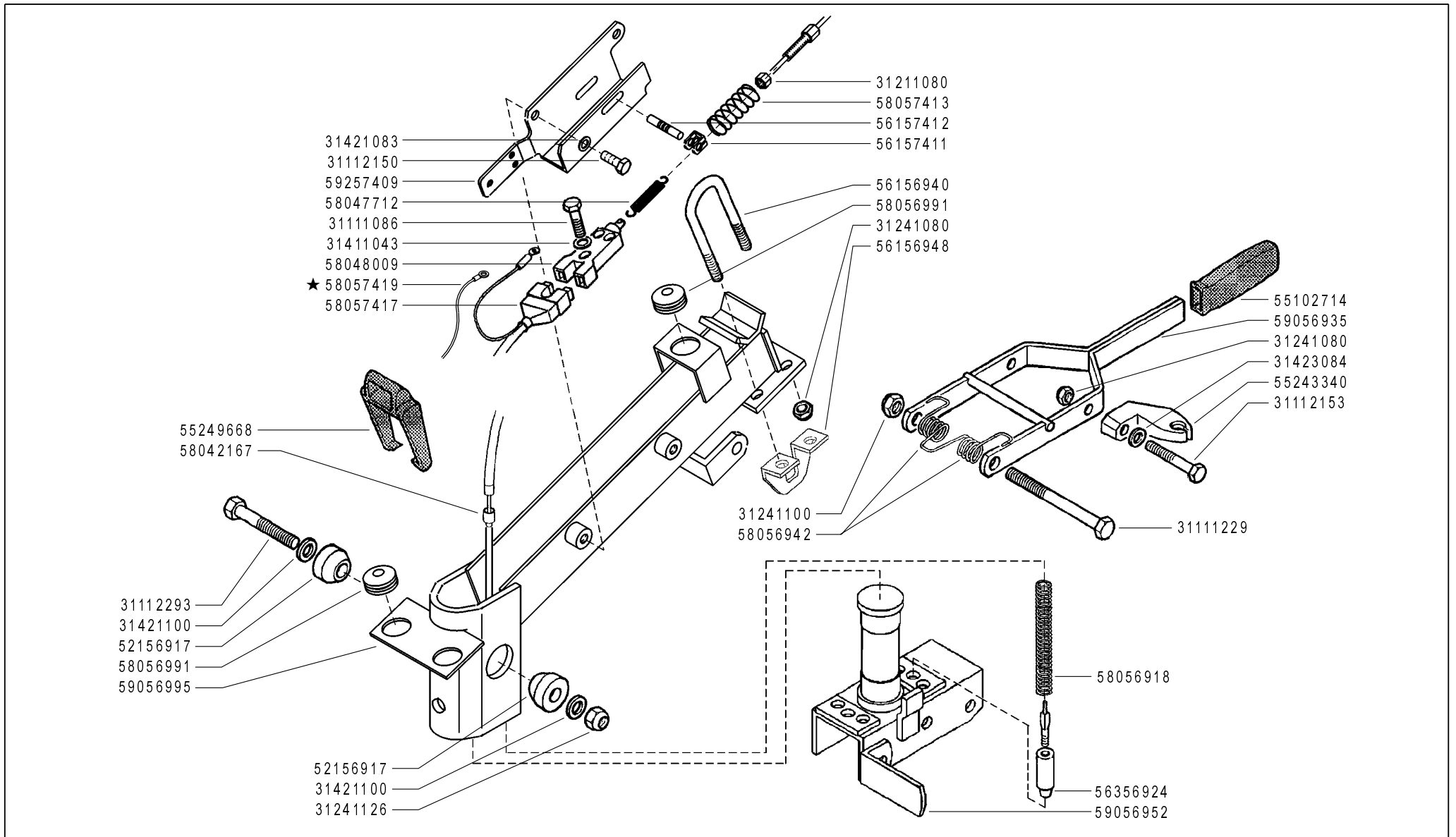

FERRARI

300 TRENDY

PIANTONE (320-330)

STEERING COLUMN
COLUMNNA

PLANTON
LENKSÄULE

DALLA MACCHINA
FROM THE MACHINE
DE LA MACHINE
DE LA MAQUINA
AB DER MASCHINE

★ N.

794196

H02 1

06/2007

Rev.

ZENNE

Pos.	Code	Q.ty	Description	Notes
59257409	59257409	1	SUPPORT	

SERIAL
START
794196

STEERING COLUMN

CODE REV
H02_1_60701

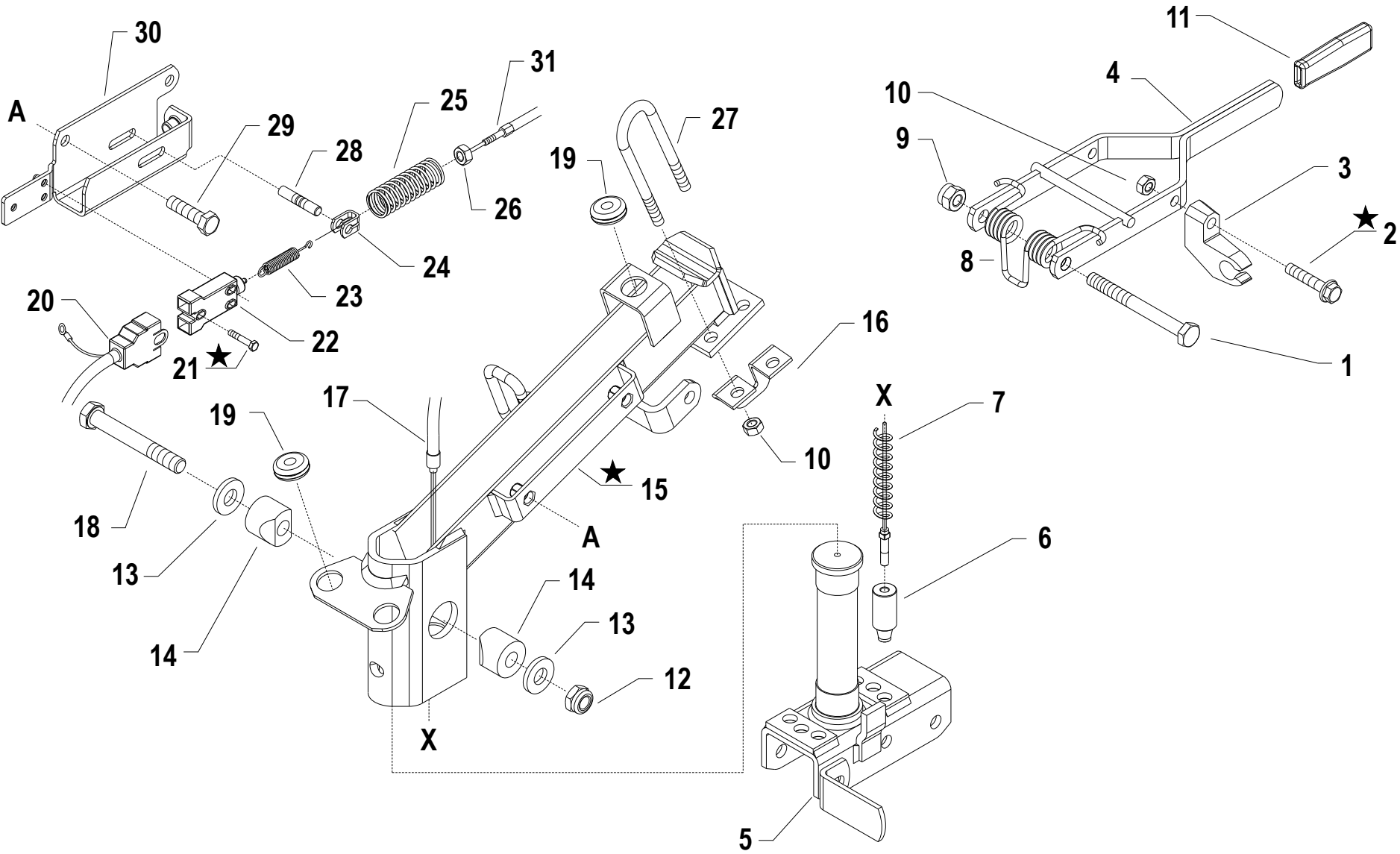

i = info - stop 2 sec. ★ = new part

Pos.	Code	Q.ty	Description	Notes
1	31111229		SCREW TE M10X110 UNI 5737 8G	
2	31112165		SCREW TE C/F M8X35 DIN 6921 8G	
3	55243340		SUPPORT	
4	59056935		LEVER	
5	59056952N		SUPPORT	
6	56356924		FERRULE	
7	58056918Z		SPRING	
8	58056942N		SPRING	
9	31241100		SELFLOCK HEXAGON NUT M10	
10	31241080		HEXAGON SELFLOCK NUT M8	
11	55102714		KNOB	
12	31241126		SELFLOCK NUT M12	
13	31421100Z		CUP SPRING	
14	52156917		WEDGE	
15	59256999		COLUMN	REPLACES 59056995
16	56156948N		STOP	
17	58042167		SHEATH TERMINAL	
18	31112293		SCREW TE M12X80 UNI 5737	
19	58056991		CABLE GLAND	
20	58057417		WIRING	
21	31121024		SCREW TBCEI FL.M4X25	
22	58048009		SWITCH	
23	58047712		SPRING	
24	56157411Z		FORK	
25	58057413		RETAINING SPRING	
26	31211080		NUT M8	
27	56156940		U BOLT	
28	56157412		PIN	
29	31112170		SCREW TE C/F M8X20 DIN 6921	
30	59257409		SUPPORT	
31	58057416		LINE AND SHEATH	

SERIAL
START
825281

STEERING COLUMN

CODE REV

H.02.01.A0027_02

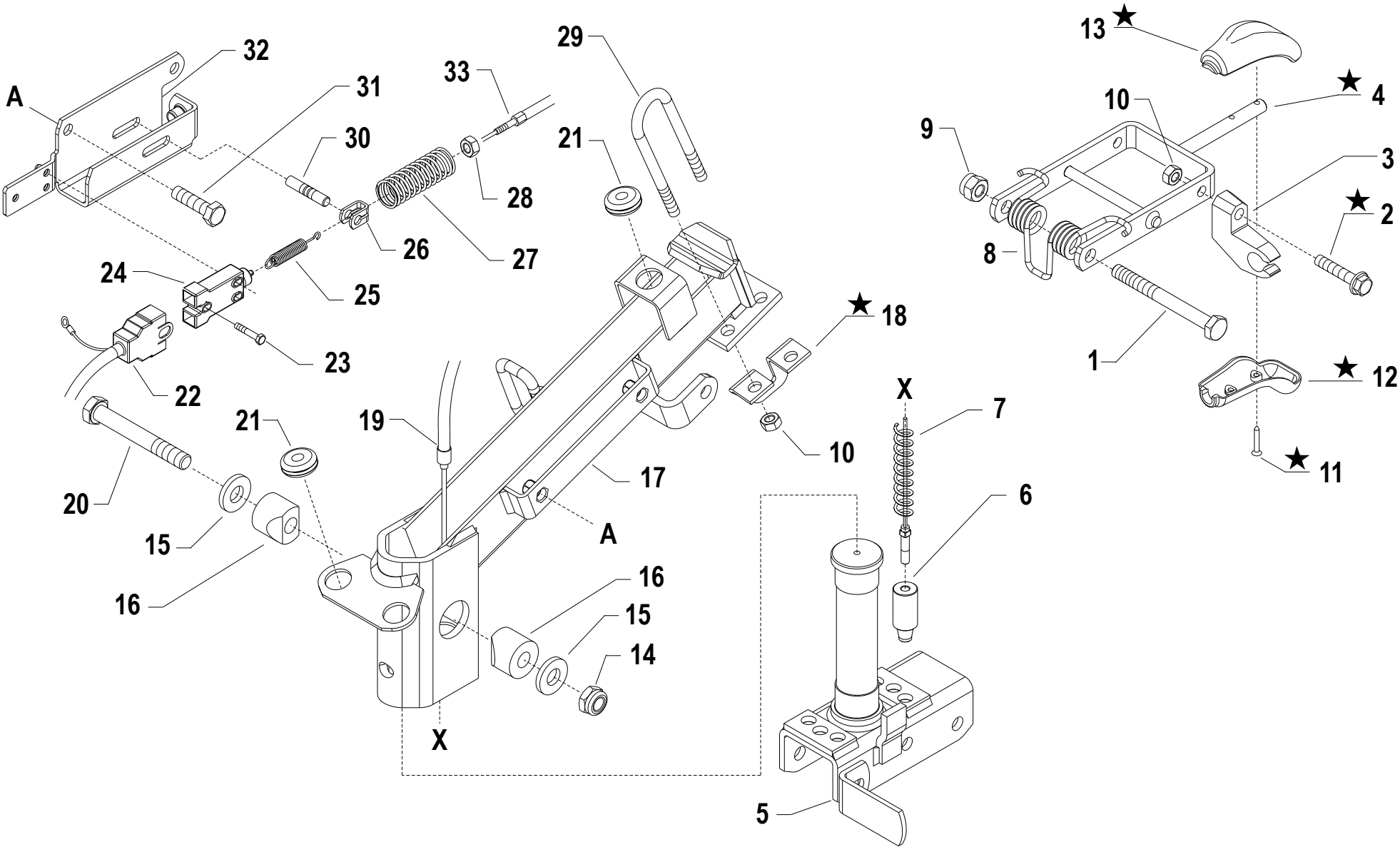

i = info - stop 2 sec. ★ = new part

Pos.	Code	Q.ty	Description	Notes
11	31100451		SCREW 3,5X25	
1	31111229		SCREW TE M10X110 UNI 5737 8G	
2	31112165		SCREW TE C/F M8X35 DIN 6921 8G	
31	31112170		SCREW TE C/F M8X20 DIN 6921	
20	31112293		SCREW TE M12X80 UNI 5737	
23	31121024		SCREW TBCEI FL.M4X25	
28	31211080		NUT M8	
10	31241080		HEXAGON SELFLOCK NUT M8	
9	31241100		SELFLOCK HEXAGON NUT M10	
14	31241126		SELFLOCK NUT M12	
15	31421100Z		CUP SPRING	
16	52156917		WEDGE	
13	55157212		GRIP	
12	55157213		GRIP	
3	55243340		SUPPORT	
29	56156940		U BOLT	
18	56156974N		SUPPORT	Sostituisce 56156948N
26	56157411Z		FORK	
30	56157412		PIN	
6	56356924		FERRULE	
19	58042167		SHEATH TERMINAL	
25	58047712		SPRING	
24	58048009		SWITCH	
7	58056918Z		SPRING	
8	58056942N		SPRING	
21	58056991		CABLE GLAND	
27	58057413		RETAINING SPRING	
33	58057416		LINE AND SHEATH	
22	58057417		WIRING	
5	59056952N		SUPPORT	
4	59057010N		LEVER	
17	59256999		COLUMN	
32	59257409		SUPPORT	

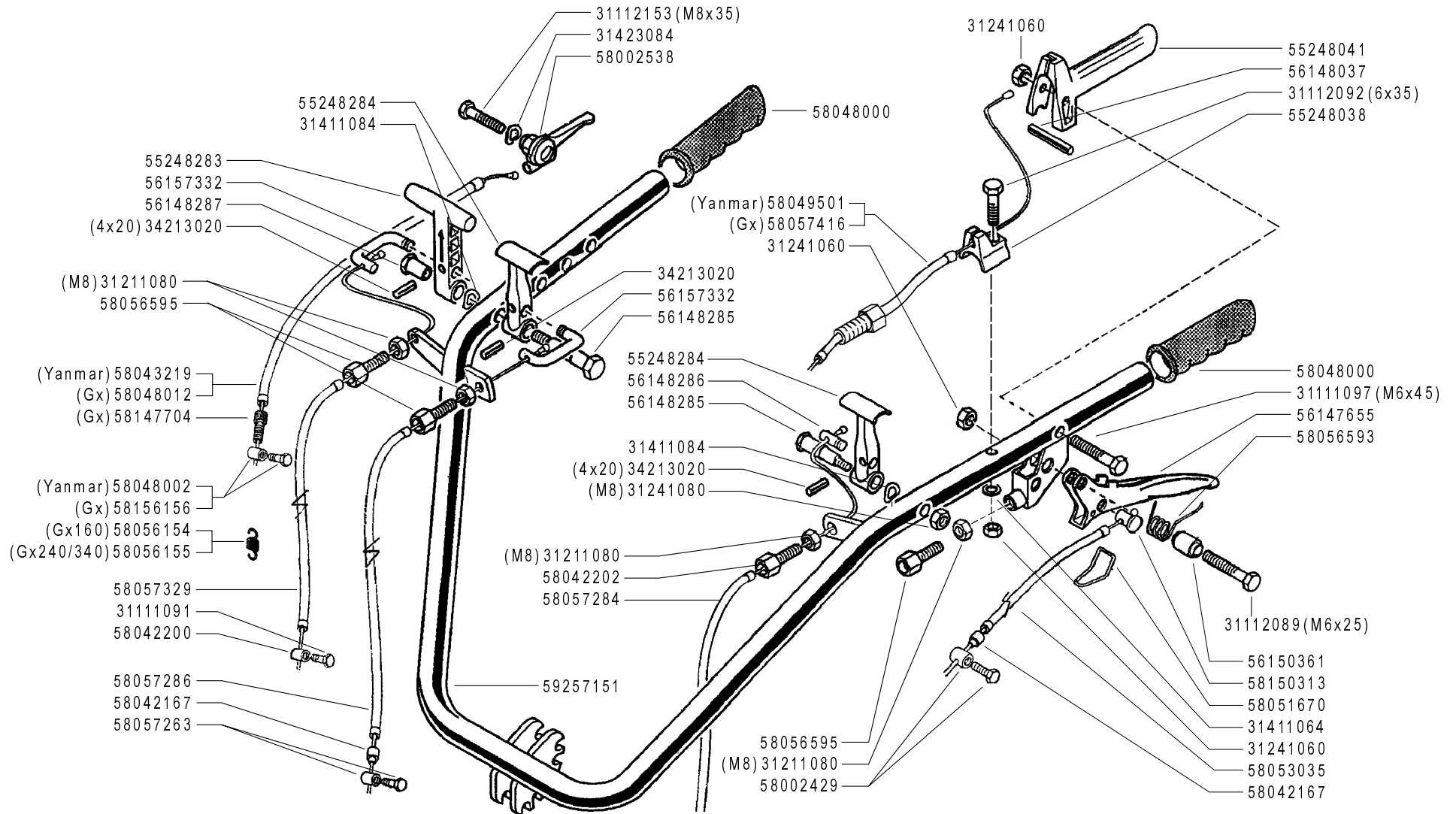

FERRARI

300 TRENDY

MANUBRIO (320-330)

HANDLEBAR
 MANILLAR

MANCHERON
 LENKER

DALLA MACCHINA
 FROM THE MACHINE
 DE LA MACHINE
 DE LA MAQUINA
 AB DER MASCHINE

N.

I02 0

11/2006

Rev.

ZENNE

Pos.	Code	Q.ty	Description	Notes
31111091	31111091	1	SCREW E M6X14 UNI 5739 8G	
31111097	31111097	1	SCREW TE M6X45 UNI 5737 8G	
31112089	31112089	1	SCREW TE M6X25 UNI 5739 8G	
31112092	31112092	1	SCREW TE M6X35 UNI 5739 8G	
31112153	31112153	1	SCREW TE M8X35 UNI 5739 8G	
31211080	31211080	1	NUT M8	
31241060	31241060	1	HEXAGON SELFLOCK NUT M6	
31241080	31241080	1	HEXAGON SELFLOCK NUT M8	
31411064	31411064	1	WASHER 6,4x12,5	
31411084	31411084	1	WASHER 8,4x17	
31423084	31423084	1	SPRING WASHER 8,4	
34213020	34213020	1	ROLL PIN	
55248038	55248038	1	STOP	
55248041	55248041	1	LEVER	
55248283	55248283	1	COMMAND LEVER	
55248284	55248284	1	LEVER	
56147655	56147655	1	CLUTCH LEVER	
56148037	56148037	1	LEVER STOP	
56148285	56148285	1	PIN	
56148286	56148286	1	PIN	
56148287	56148287	1	STUD BOLT	
56150361	56150361	1	SPACER	
56157332	56157332	1	U BOLT	
58002429	58002429	1	CLAMPING SCREW	
58002538	58002538	1	COMMAND LEVER	
58042167	58042167	1	SHEATH TERMINAL	
58042200	58042200	1	CLAMPING SCREW	
58042202	58042202	1	ADJUSTING SCREW	
58043219	58043219	1	LINE AND SHEATH	
58048000	58048000	1	KNOB	
58048002	58048002	1	CLAMPING SCREW	
58048012	58048012	1	LINE AND SHEATH	
58049501	58049501	1	LINE AND SHEATH	
58051670	58051670	1	CLEVIS	

SERIAL

HANDLEBAR

CODE REV

I02_0_27387

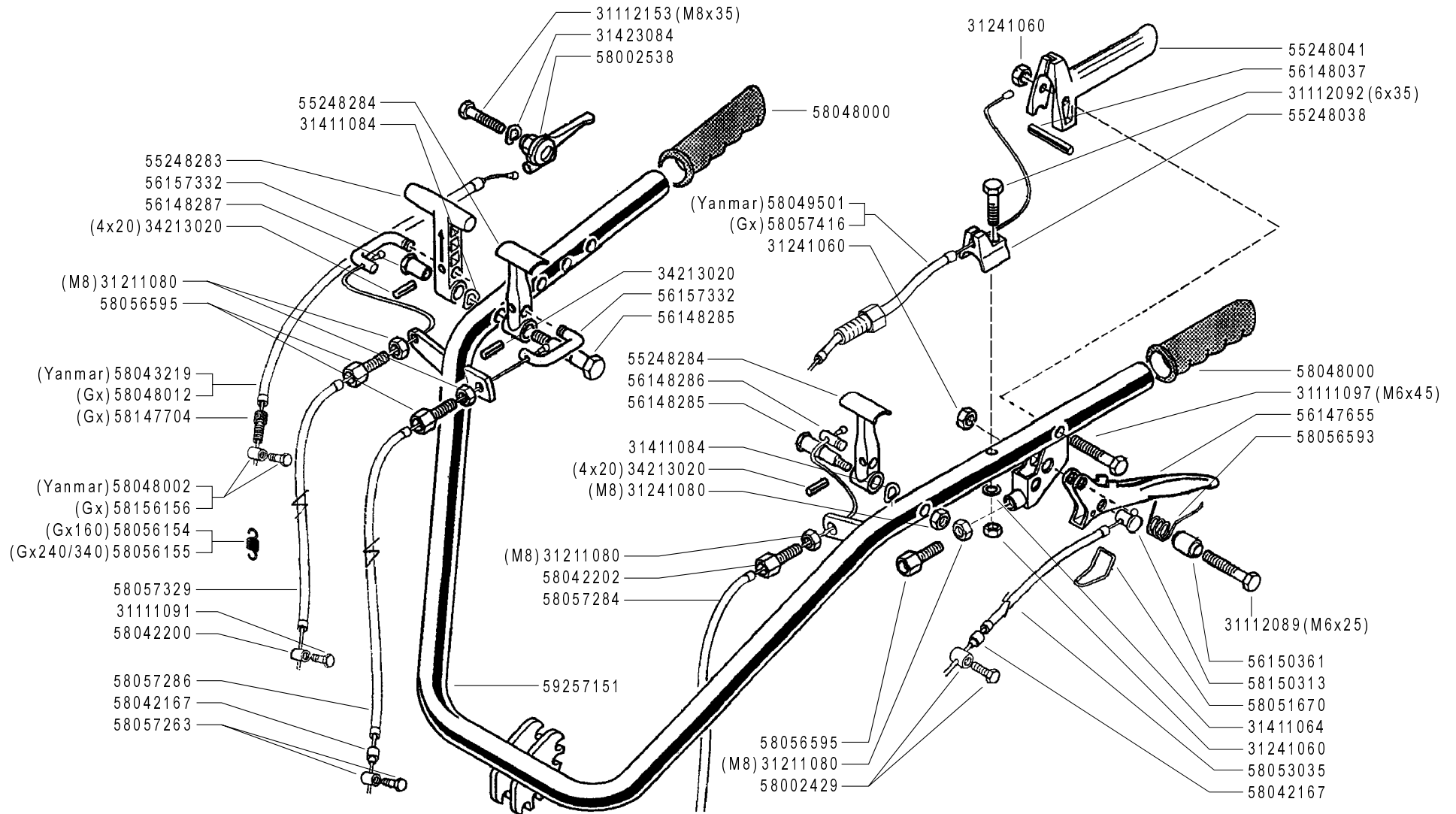

FERRARI

300 TRENDY

MANUBRIO (320-330)

HANDLEBAR
 MANILLAR

MANCHERON
 LENKER

DALLA MACCHINA
 FROM THE MACHINE
 DE LA MACHINE
 DE LA MAQUINA
 AB DER MASCHINE

N.

I02 0

11/2006

Rev.

ZENNE

Pos.	Code	Q.ty	Description	Notes
58053035	58053035	1	LINE AND SHEATH	
58056154	58056154	1	RESTORING SPRING	Utilizzato con motore GX200
58056155	58056155	1	RESTORING SPRING	Utilizzato con motore GX270
58056593	58056593	1	SPRING	
58056595	58056595	1	ADJUSTING SCREW	
58057263	58057263	1	CLAMPING SCREW	
58057284	58057284	1	LINE AND SHEATH	
58057286	58057286	1	LINE AND SHEATH	
58057329	58057329	1	LINE AND SHEATH	
58057416	58057416	1	LINE AND SHEATH	
58147704	58147704	1	ADJUSTING SCREW	
58150313	58150313	1	CABLE CLAMP	
58156156	58156156	1	TERMINAL	
59257151	59257151	1	COMPLETE HANDLE BAR	

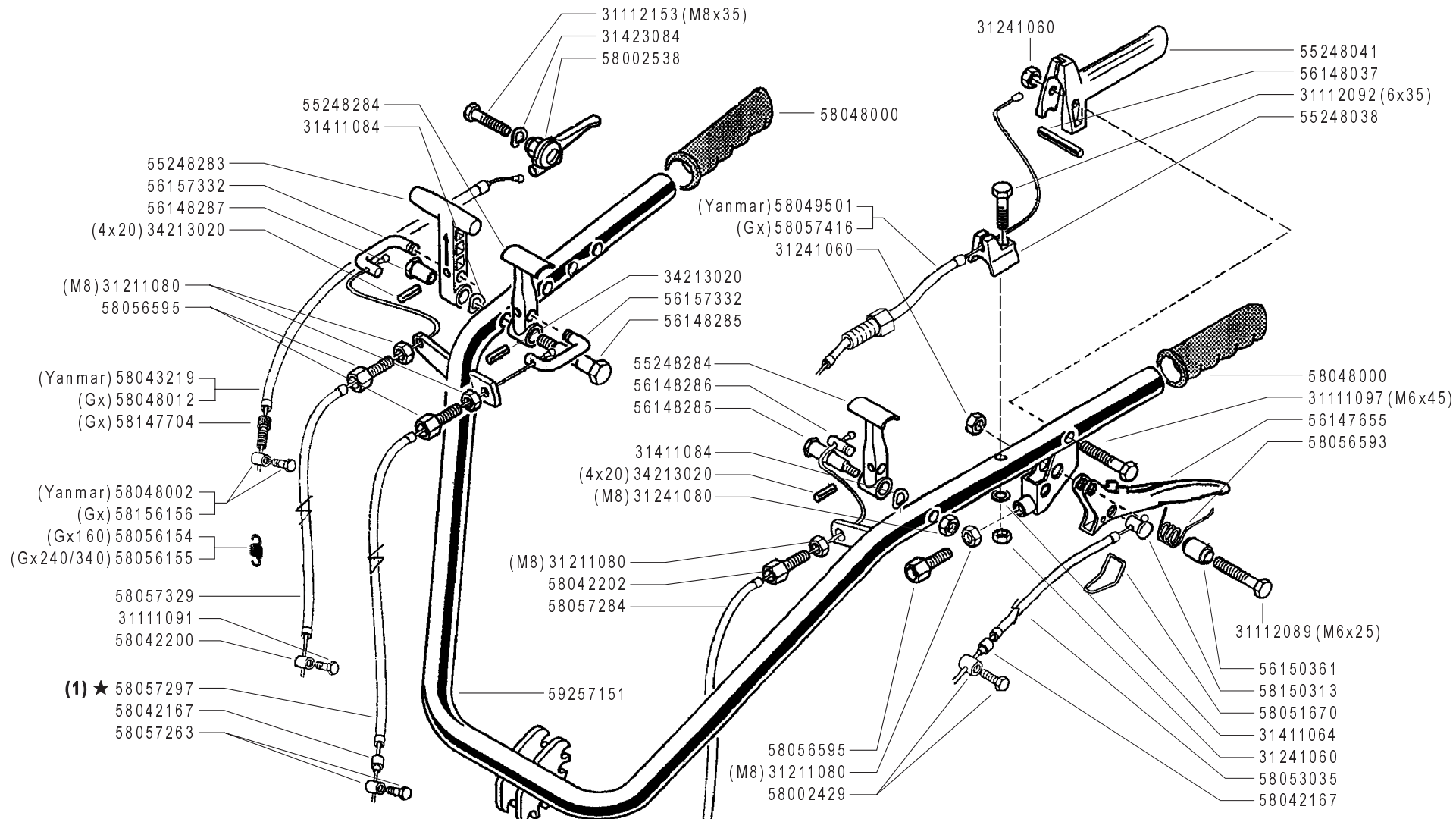

(1) sostituisce 58057286

	<h1>300 TRENDY</h1>	MANUBRIO (320-330) HANDLEBAR MANILLAR	DALLA MACCHINA FROM THE MACHINE DE LA MACHINE DE LA MAQUINA AB DER MASCHINE	AGGIORNAMENTO	I02	Rev.
				REVISION		1
				MISE A JOUR		
				APLAZAMIENTO		
				ANPASSUNG		
			★ N.	06/2007	ZENNE	

Pos.	Code	Q.ty	Description	Notes
31111091	31111091	1	SCREW E M6X14 UNI 5739 8G	
31111097	31111097	1	SCREW TE M6X45 UNI 5737 8G	
31112089	31112089	1	SCREW TE M6X25 UNI 5739 8G	
31112092	31112092	1	SCREW TE M6X35 UNI 5739 8G	
31112153	31112153	1	SCREW TE M8X35 UNI 5739 8G	
31211080	31211080	1	NUT M8	
31241060	31241060	1	HEXAGON SELFLOCK NUT M6	
31241080	31241080	1	HEXAGON SELFLOCK NUT M8	
31411064	31411064	1	WASHER 6,4x12,5	
31411084	31411084	1	WASHER 8,4x17	
31423084	31423084	1	SPRING WASHER 8,4	
34213020	34213020	1	ROLL PIN	
55248038	55248038	1	STOP	
55248041	55248041	1	LEVER	
55248283	55248283	1	COMMAND LEVER	
55248284	55248284	1	LEVER	
56147655	56147655	1	CLUTCH LEVER	
56148037	56148037	1	LEVER STOP	
56148285	56148285	1	PIN	
56148286	56148286	1	PIN	
56148287	56148287	1	STUD BOLT	
56150361	56150361	1	SPACER	
56157332	56157332	1	U BOLT	
58002429	58002429	1	CLAMPING SCREW	
58002538	58002538	1	COMMAND LEVER	
58042167	58042167	1	SHEATH TERMINAL	
58042200	58042200	1	CLAMPING SCREW	
58042202	58042202	1	ADJUSTING SCREW	
58043219	58043219	1	LINE AND SHEATH	
58048000	58048000	1	KNOB	
58048002	58048002	1	CLAMPING SCREW	
58048012	58048012	1	LINE AND SHEATH	
58049501	58049501	1	LINE AND SHEATH	
58051670	58051670	1	CLEVIS	

SERIAL

HANDLEBAR

CODE REV

I02_1_45506

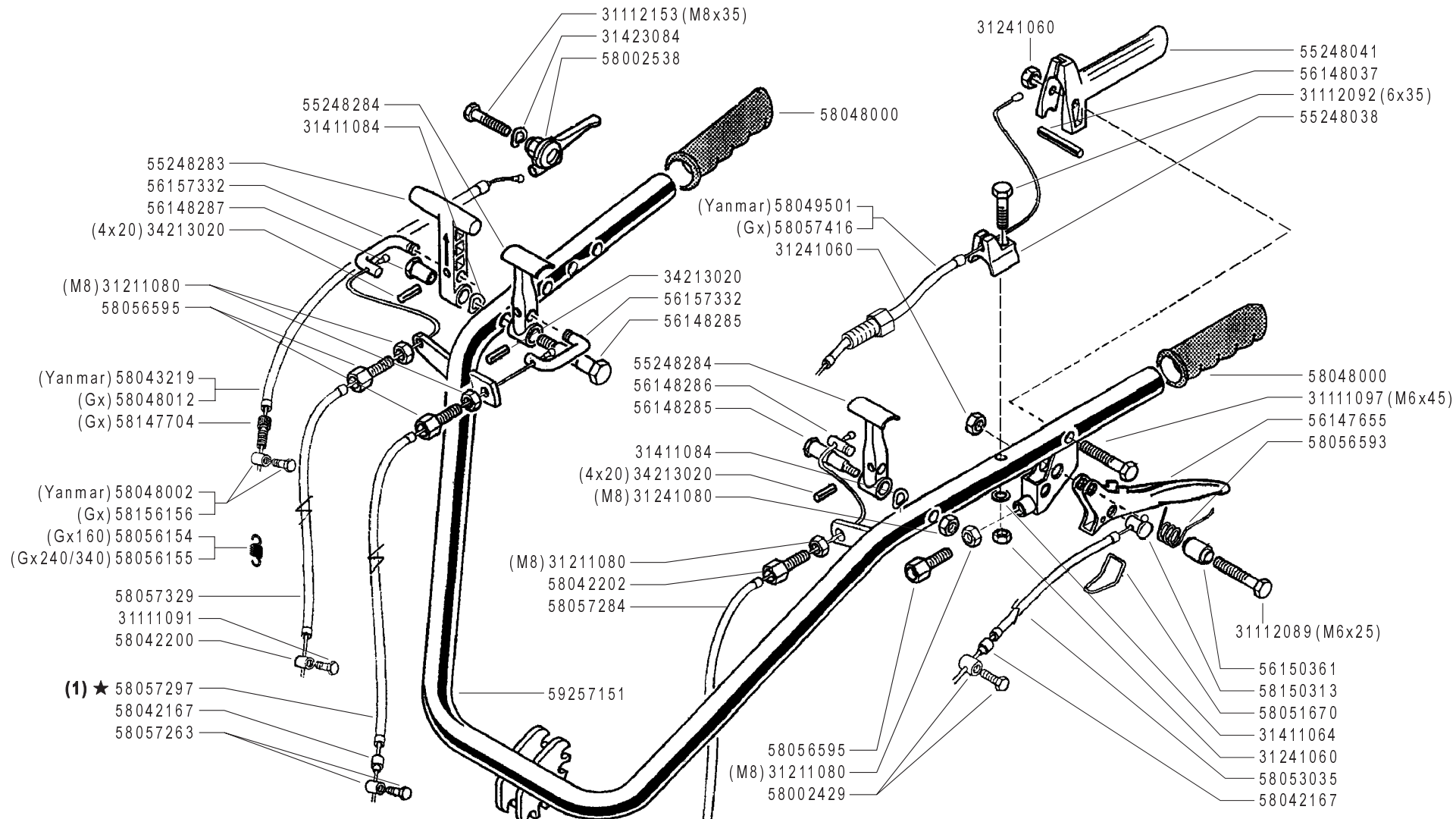

(1) sostituisce 58057286

	<h1>300 TRENDY</h1>	MANUBRIO (320-330) HANDLEBAR MANILLAR	DALLA MACCHINA FROM THE MACHINE DE LA MACHINE DE LA MAQUINA AB DER MASCHINE	AGGIORNAMENTO	I02	Rev.
				REVISION		1
				MISE A JOUR		
				APLAZAMIENTO		
				ANPASSUNG		

★ N.

ZENNE

Pos.	Code	Q.ty	Description	Notes
58053035	58053035	1	LINE AND SHEATH	
58056154	58056154	1	RESTORING SPRING	Utilizzato con motore GX200
58056155	58056155	1	RESTORING SPRING	Utilizzato con motore GX270
58056593	58056593	1	SPRING	
58056595	58056595	1	ADJUSTING SCREW	
58057263	58057263	1	CLAMPING SCREW	
58057284	58057284	1	LINE AND SHEATH	
58057297	58057297	1	LINE AND SHEATH	
58057329	58057329	1	LINE AND SHEATH	
58057416	58057416	1	LINE AND SHEATH	
58147704	58147704	1	ADJUSTING SCREW	
58150313	58150313	1	CABLE CLAMP	
58156156	58156156	1	TERMINAL	
59257151	59257151	1	COMPLETE HANDLE BAR	

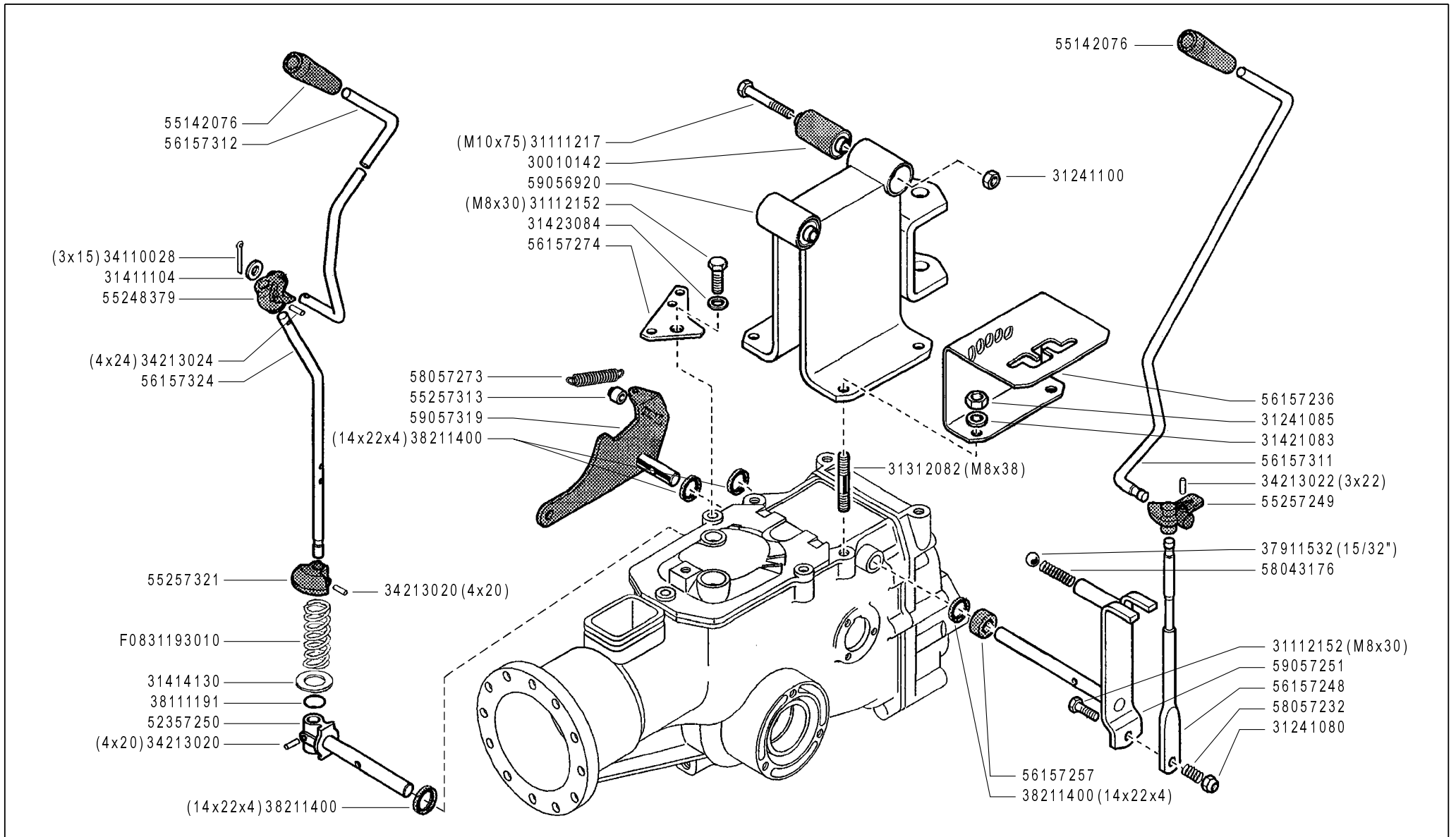

FERRARI

300 TRENDY

COMANDI (320-330)

CONTROLS
MANDOS

COMMANDES
ANTRIEBE

DALLA MACCHINA
FROM THE MACHINE
DE LA MACHINE
DE LA MAQUINA
AB DER MASCHINE

N.

J02 0

11/2006

Rev.

ZENNE

Pos.	Code	Q.ty	Description	Notes
30010142	30010142	1	SILENT-BLOCK 10,2X30X45X49	
31111217	31111217	1	SCREW TE M10X75 UNI 5737 8G	
31112152	31112152	1	SCREW TE M8X30 UNI 5739 8G	
31241080	31241080	1	HEXAGON SELFLOCK NUT M8	
31241085	31241085	1	SELFLOCK NUT M8 6S	
31241100	31241100	1	SELFLOCK HEXAGON NUT M10	
31312082	31312082	1	STUD BOLT M8X38X14X20	
31411104	31411104	1	WASHER 10,5x18	
31414130	31414130	1	WASHER 13	
31421083	31421083	1	WASHER	
31423084	31423084	1	SPRING WASHER 8,4	
34110028	34110028	1	SPLIT PIN	
34213020	34213020	1	ROLL PIN	
34213022	34213022	1	ROLL PIN	
34213024	34213024	1	ROLL PIN	
37911532	37911532	1	BALL 15/32	
38111191	38111191	1	O-RING	
38211400	38211400	1	OIL SEAL 14X22X4	
52357250	52357250	1	PIN	
55142076	55142076	1	KNOB	
55248379	55248379	1	JOINT	
55257249	55257249	1	JOINT	
55257313	55257313	1	ROLLER	
55257321	55257321	1	STOP	
56157236	56157236	1	GEAR SELECTOR	
56157248	56157248	1	COMMAND LEVER	
56157257	56157257	1	SPACER	
56157274	56157274	1	SQUARE	
56157311	56157311	1	GEARSHIFT ROD	
56157312	56157312	1	ROD	
56157324	56157324	1	PTO LEVER	
58043176	58043176	1	SPRING	
58057232	58057232	1	SPRING	
58057273	58057273	1	SPRING	

SERIAL

CONTROLS

CODE REV

J02_0_27474

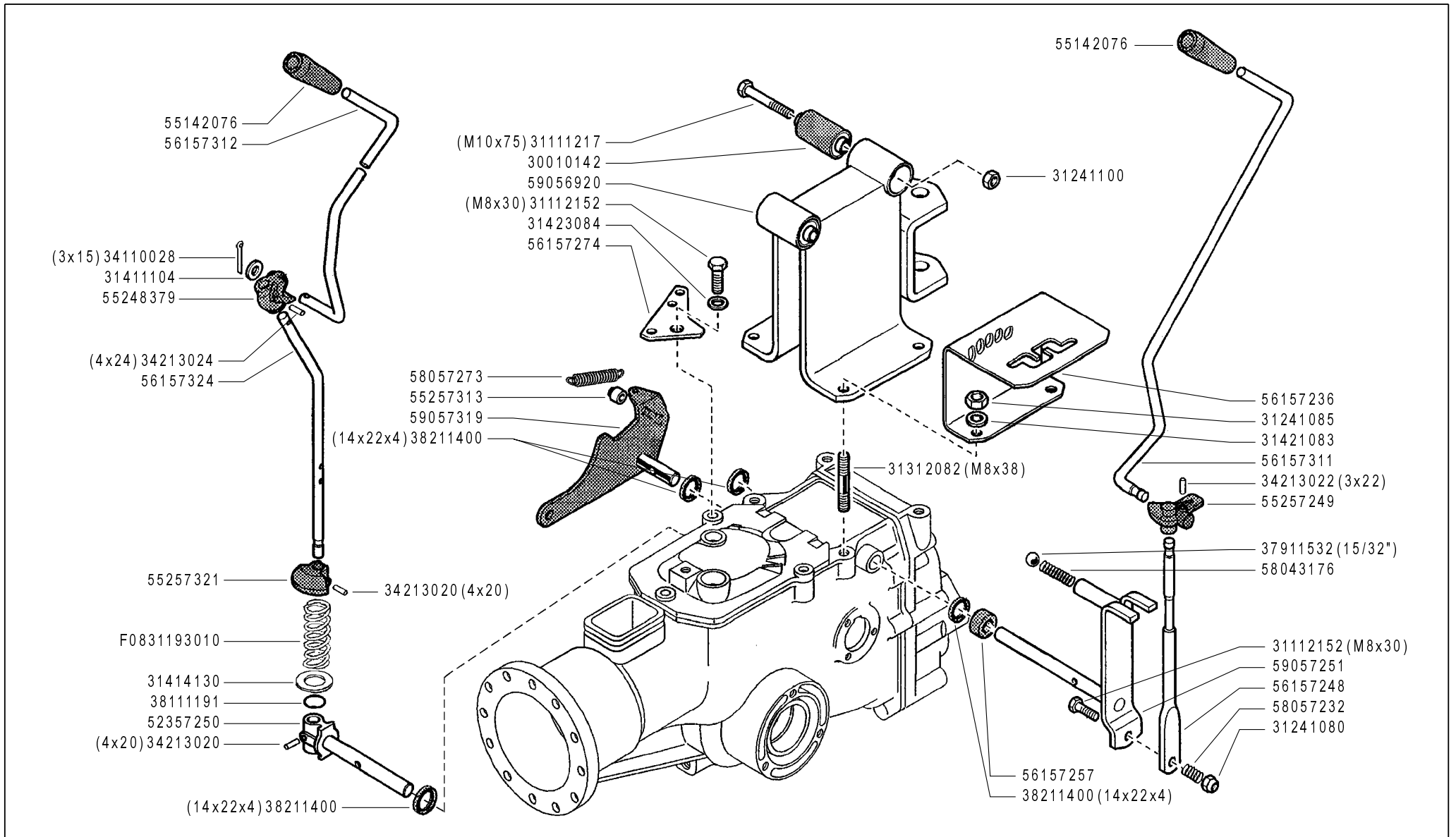

FERRARI

300 TRENDY

COMANDI (320-330)

CONTROLS
MANDOS

COMMANDES
ANTRIEBE

DALLA MACCHINA
FROM THE MACHINE
DE LA MACHINE
DE LA MAQUINA
AB DER MASCHINE

N.

J02 0

11/2006

Rev.

ZENNE

Pos.	Code	Q.ty	Description	Notes
59056920	59056920	1	SUPPORT	
59057251	59057251	1	GEAR LEVER	
59057319	59057319	1	LEVER	
F0831193	F0831193010	1	SPRING DM.15X70	

HANDLEBAR

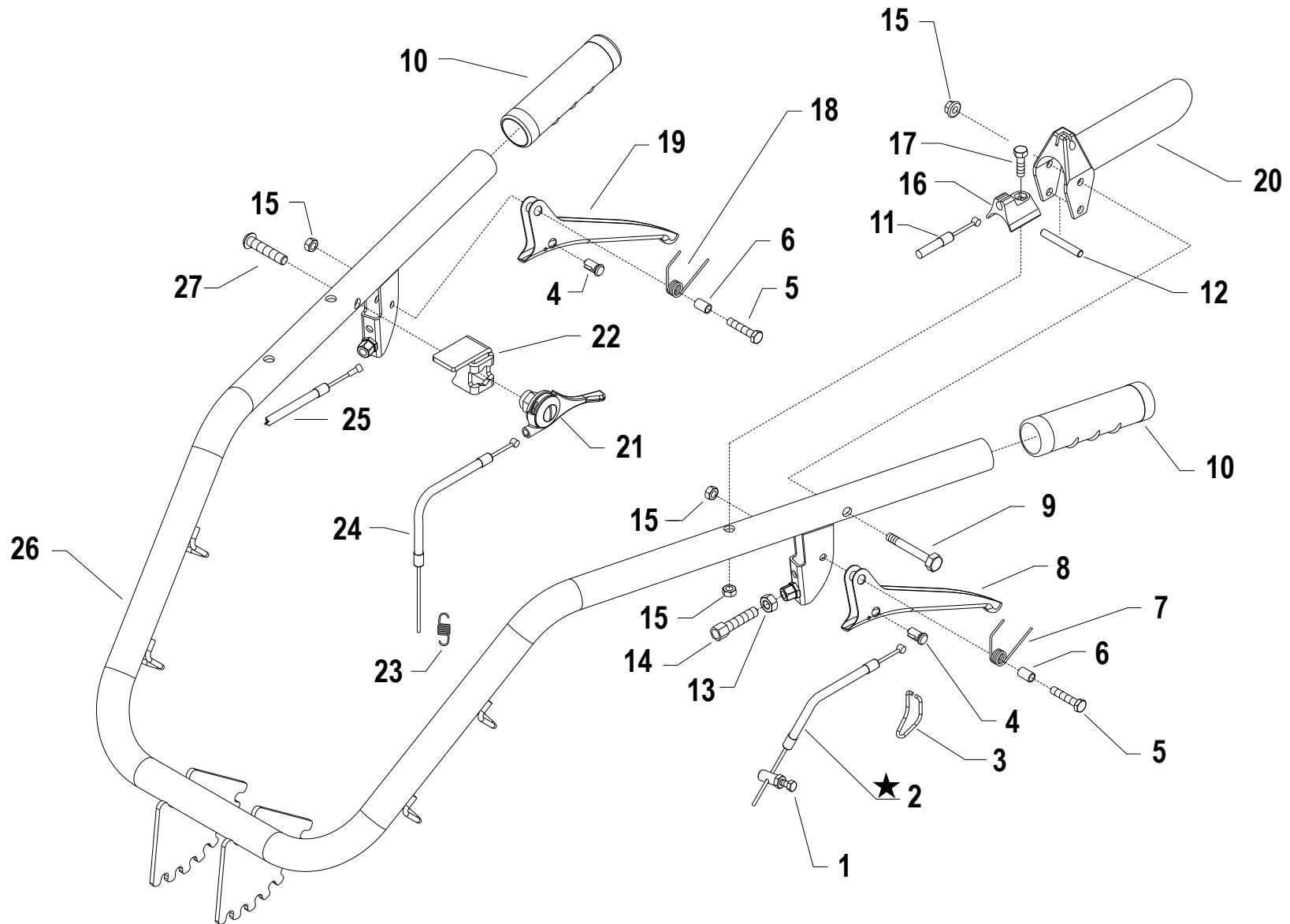

i = info - stop 2 sec. ★ = new part

Pos.	Code	Q.ty	Description	Notes
1	58042200		CLAMPING SCREW	
2	58057285		LINE AND SHEATH	REPLACES 58053035
3	58051670		CLEVIS	
4	58150313		CABLE CLAMP	
5	31112089		SCREW TE M6X25 UNI 5739 8G	
6	56156603Z		SPACER	
7	58050345		SPRING	
8	56147655N		CLUTCH LEVER	
9	31111097		SCREW TE M6X45 UNI 5737 8G	
10	58048000		KNOB	
11	58048355		LINE AND SHEATH	DIESEL
11	58057418		LINE AND SHEATH	
12	56148037		LEVER STOP	
13	31211080		NUT M8	
14	58056595		ADJUSTING SCREW	
15	31241060		HEXAGON SELFLOCK NUT M6	
16	55248038		STOP	
17	31112092		SCREW TE M6X35 UNI 5739 8G	
18	58056593		SPRING	
19	56148470N		LEVER	
20	55248041		LEVER	
21	58002538		COMMAND LEVER	
22	56156874N		PANEL	
23	58056154		RESTORING SPRING	Utilizzato con motore GX200 - GX200
23	58056155		RESTORING SPRING	Utilizzato con motore GX270 - GX240/GX270/GX340
24	58056815		LINE AND SHEATH	GX200/GX270
25	58056193		COLUMN TRANSMISSION	
26	59257162		HANDLE BAR	
27	31121020		SCREW TBCEI M8X40 ISO7380 10K Z	

SERIAL
START
963640

HANDLEBAR

CODE REV
I.02.01.A0027_02

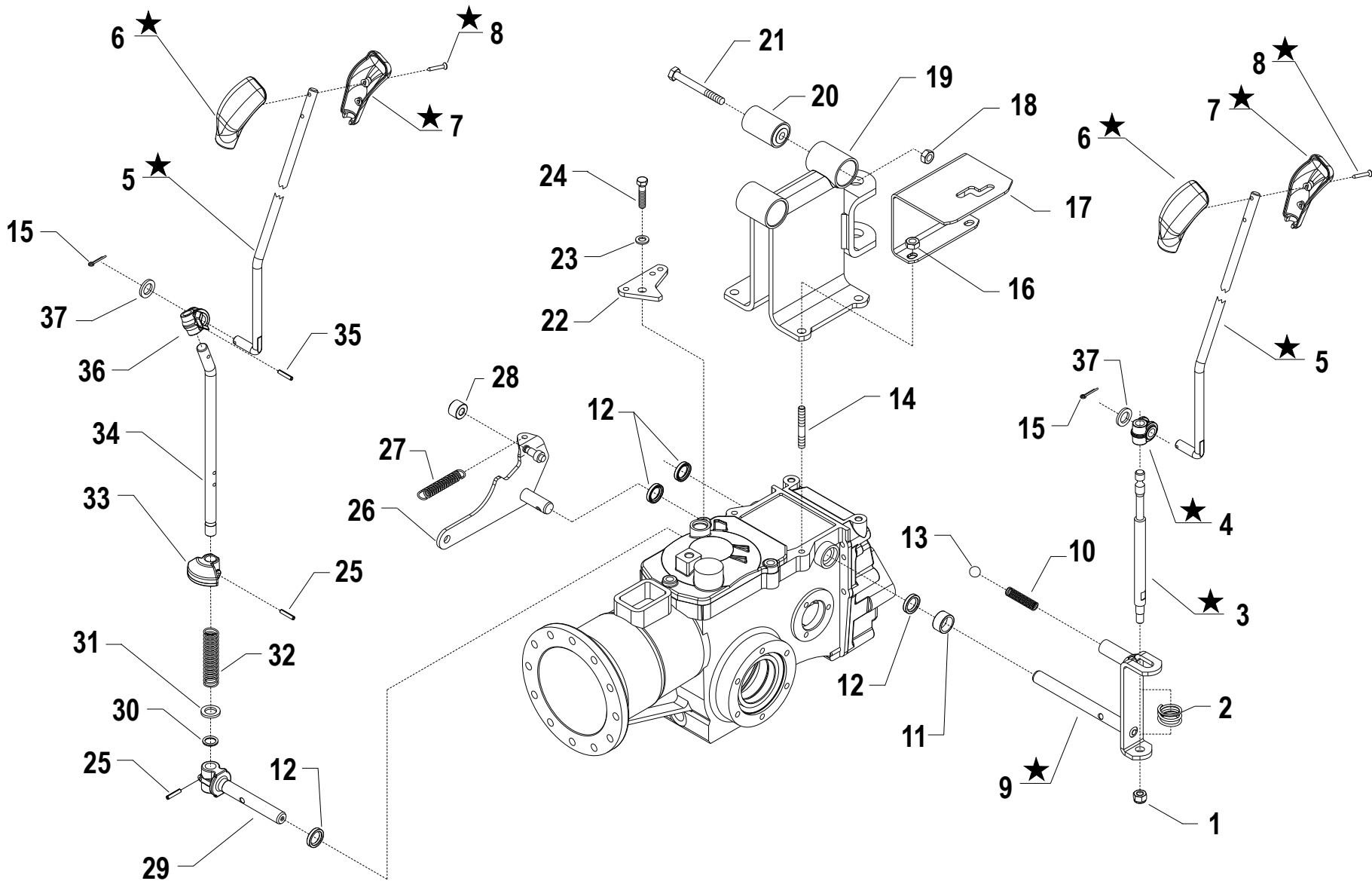

i = info - stop 2 sec. ★ = new part

Pos.	Code	Q.ty	Description	Notes
1	31241080		HEXAGON SELFLOCK NUT M8	
2	58057232Z		SPRING	
3	563C1005Z		COMMAND LEVER	REPLACES 56157248N + 59057251N
4	55242528		JOINT	
5	56156792Z		PULL ROD	
6	55157212		GRIP	
7	55157213		GRIP	
8	31100451		SCREW 3,5X25	
9	59056735N		GEAR LEVER	REPLACES 56157248N + 59057251N
10	58043176		SPRING	
11	56157257Z		SPACER	
12	38211400		OIL SEAL 14X22X4	
13	37911532		BALL 15/32	
14	31312082		STUD BOLT M8X38X14X20	
15	34110028		SPLIT PIN	
16	31241084		SELFLOCK NUT M8 6S	
17	56156195H		GEAR SELECTOR	
18	31241100		SELFLOCK HEXAGON NUT M10	
19	59056920		SUPPORT	
20	30010142		SILENT-BLOCK 10,2X30X45X49	
21	31111217		SCREW TE M10X75 UNI 5737 8G	
22	56157274		SQUARE	
23	31423084		SPRING WASHER 8,4	
24	31112152		SCREW TE M8X30 UNI 5739 8G	
25	34213020		ROLL PIN	
26	59057319		LEVER	
27	58057273		SPRING	
28	55257313		ROLLER	
29	52357250		PIN	
30	38111191		O-RING	
31	31414130		WASHER 13	
32	F0831193010		SPRING DM.15X70	
33	55257321		STOP	
34	56157324N		PTO LEVER	

SERIAL
START
963640

CONTROLS

CODE REV

J.02.01.A0027_01

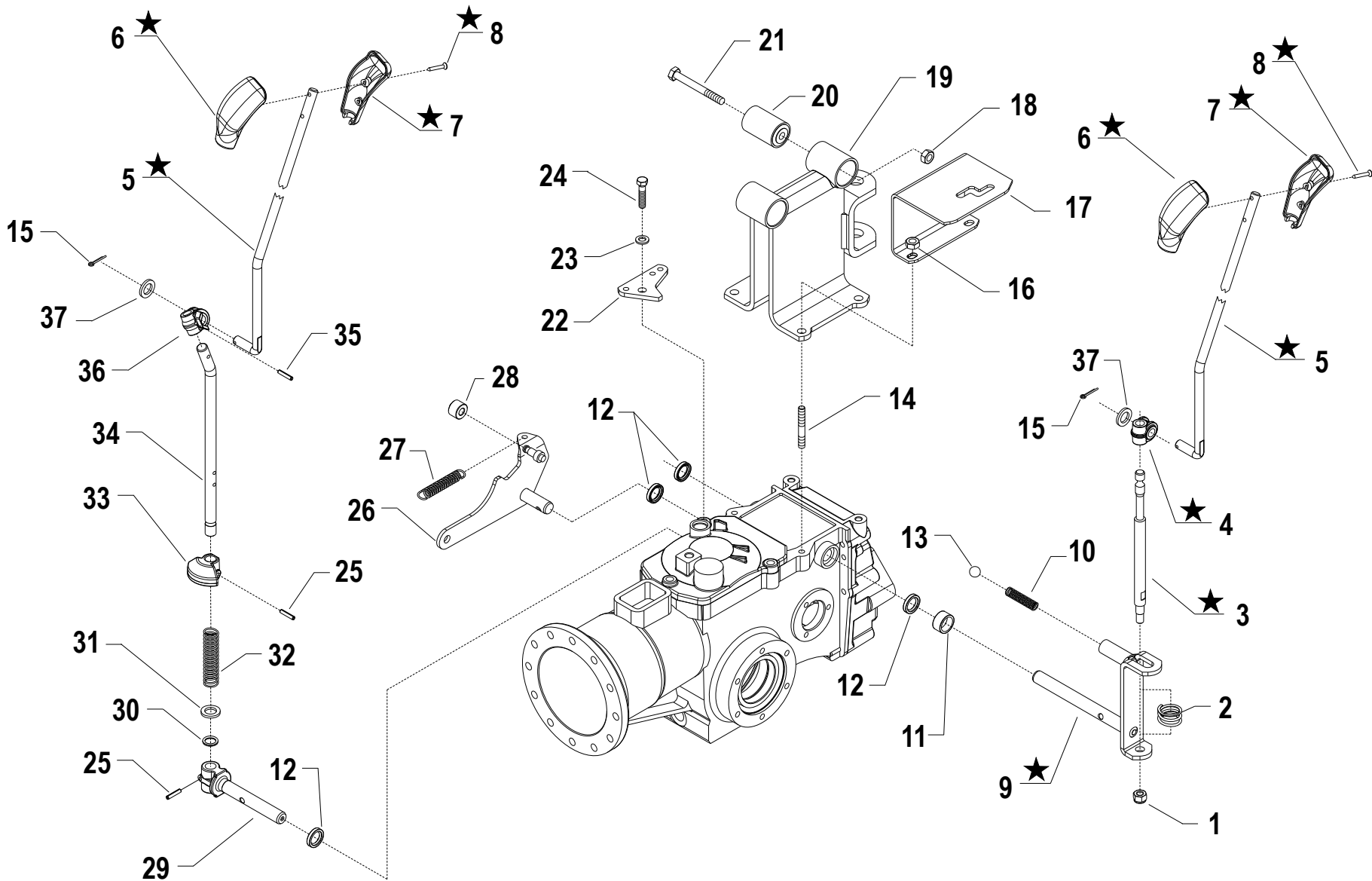

i = info - stop 2 sec. ★ = new part

Pos.	Code	Q.ty	Description	Notes
35	34213024		ROLL PIN	
36	55248379		JOINT	
37	31411104		WASHER 10,5x18	

SERIAL
START
963640

CONTROLS

CODE REV
J.02.01.A0027_01

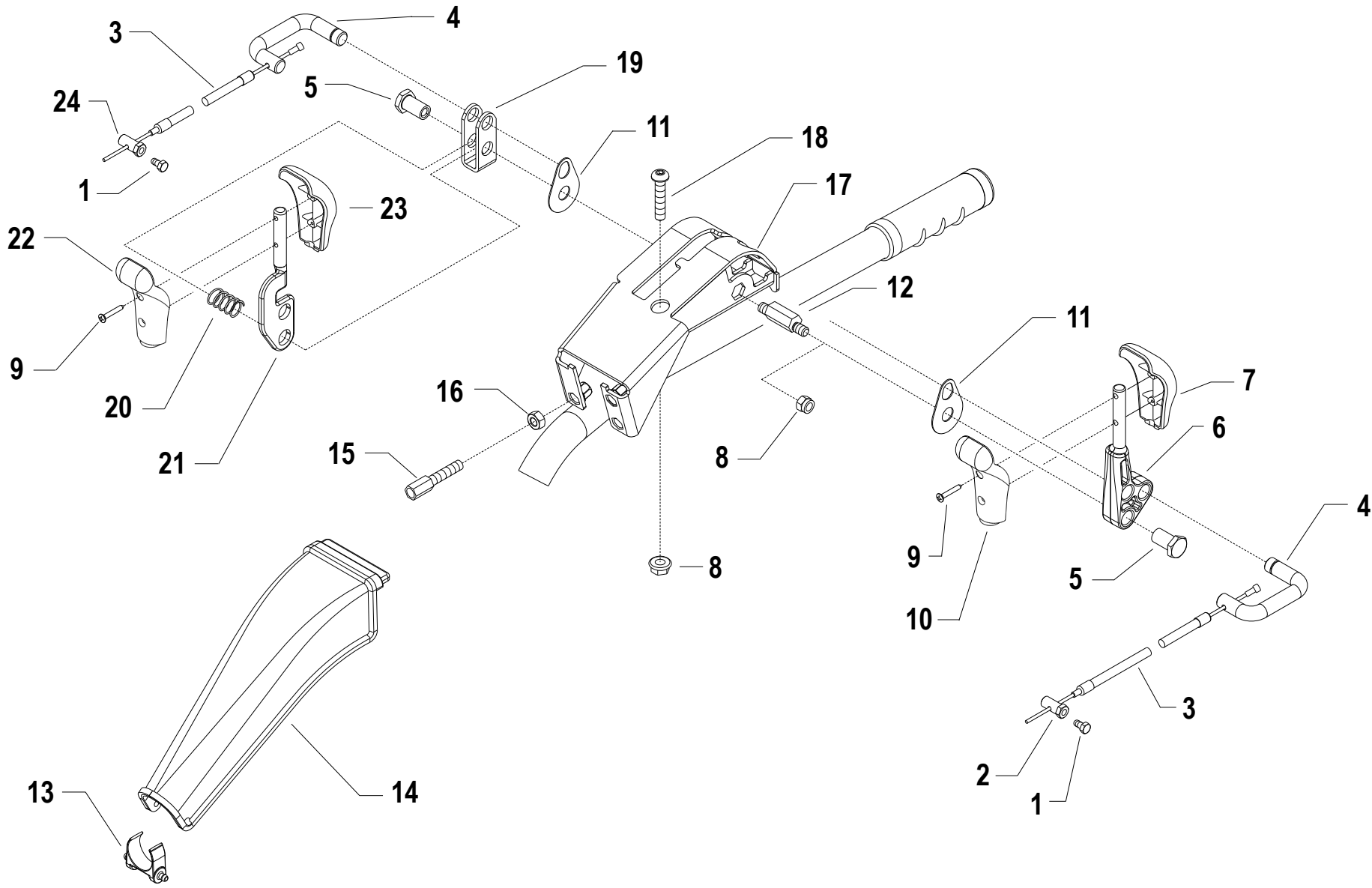

i = info - stop 2 sec. ★ = new part

Pos.	Code	Q.ty	Description	Notes
1	31112090		SCREW TE M6X16 UNI 5739 8G	
2	56356840Z		CLAMPING SCREW	
3	58056848		LINE AND SHEATH	
4	56156832Z		U BOLT	
5	56148287		STUD BOLT	
6	53156860		COMMAND LEVER	
7	55157212		GRIP	
8	31241084		SELFLOCK NUT M8 6S	
9	31100451		SCREW 3,5X25	
10	55157213		GRIP	
11	56356833Z		SMALL PLATE	
12	56356858Z		PIN	
13	55256836		CROSS MEMBER	
14	55256835		PROTECTION COVER	
15	58056595		ADJUSTING SCREW	
16	31211080		NUT M8	
17	59256850		SUPPORT	
18	31121020		SCREW TBCEI M8X40 ISO7380 10K Z	
19	56156859Z		FORK	
20	58049830		SPRING	
21	52156810Z		COMMAND LEVER	
22	55157215		GRIP	
23	55157214		GRIP	
24	58042200		CLAMPING SCREW	

SERIAL
START
963640

HANDLEBAR CONTROLS

CODE REV
J.04.01.A0027_00

	A	B	C	D
3.50 - 8"	39113502	39413502	58052326	92243686 (Kg.10)
4.00 - 8"	39114008	39414008	58052326	92243686 (Kg.10)
4.0 - 10"	39114010	39414010	58052327	92248715 (Kg.15)
5.0 - 10"	39115010	39415010	58052327	92248715 (Kg.15)
5.00 - 12"	39115012	39415012	58052328	92248720 (Kg.34)

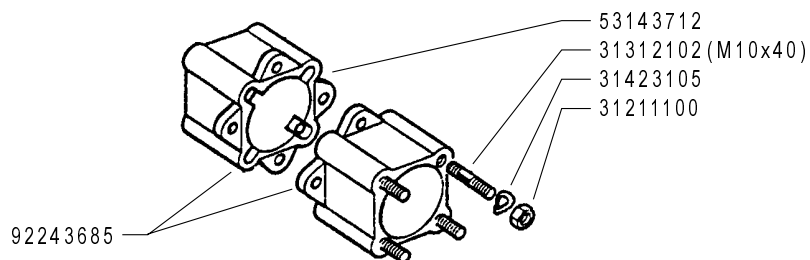
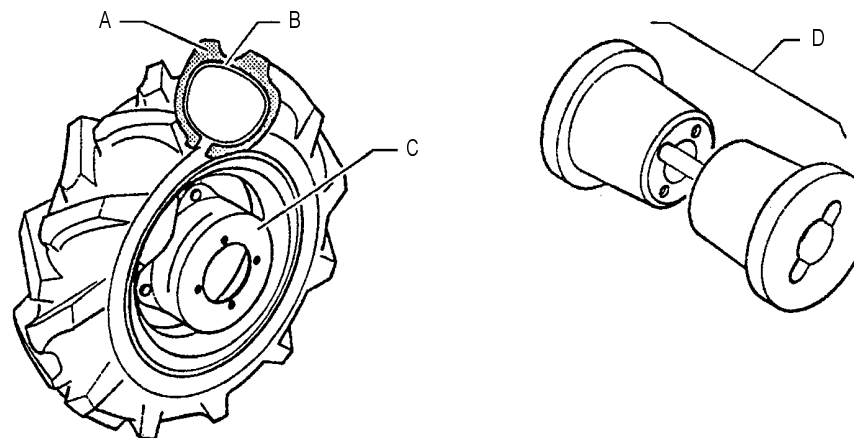

FERRARI

300 TRENDY

RUOTE

WHEELS
RUEDAS

ROUES
RÄDER

DALLA MACCHINA
FROM THE MACHINE
DE LA MACHINE
DE LA MAQUINA
AB DER MASCHINE

N.

K01 0

11/2006

Rev.

ZENNE

Pos.	Code	Q.ty	Description	Notes
31211100	31211100	1	NUT M10	
31312102	31312102	1	STUD BOLT M10X40X24X12	
31423105	31423105	1	SPRING WASHER 10,5	
39113502	39113502	1	TYRE 3.50-8 2PR	
39114008	39114008	1	TYRE 4.00-8 2PR	
39114010	39114010	1	TYRE 4.0-10 2PR	
39115010	39115010	1	TYRE 5.00-10 2PR	
39115012	39115012	1	TYRE 5.00-12 2PR	
39413502	39413502	1	INNER TUBE	
39414008	39414008	1	INNER TUBE	
39414010	39414010	1	INNER TUBE	
39415010	39415010	1	INNER TUBE	
39415012	39415012	1	INNER TUBE	
53143712	53143712	1	SPACER	
58052326	58052326	1	RIM	
58052327	58052327	1	RIM	
58052328	58052328	1	RIM	
92243685	92243685	1	PAIR WHEEL SPACERS 6 CM	
92243686	92243686	1	PAIR OF WEIGHTS FOR 8 WHEELS 11 KGS	
92248715	92248715	1	PAIR OF WEIGHTS FOR 10 WHEELS 15 KGS	
92248720	92248720	1	PAIR OF WEIGHTS FOR 12 AND 15 WHEELS - 34 KGS	

	A	B	C	D	
	3.50 - 8"	39113502	39413502	58052326	92243686 (Kg.10)
	4.00 - 8"	39114008	39414008	58052326	92243686 (Kg.10)
★	4.0 - 10"	39114010	39414010	58052288 (FIX)	/
	4.0 - 10"	39114010	39414010	58052327	92248715 (Kg.15)
★	5.0 - 10"	39115010	39415010	58052288 (FIX)	/
	5.0 - 10"	39115010	39415010	58052327	92248715 (Kg.15)
	5.00 - 12"	39115012	39415012	58052328	92248720 (Kg.34)
★	6.5/80 - 12"	39116018	39416018	58052328	92480721 (Kg.34)

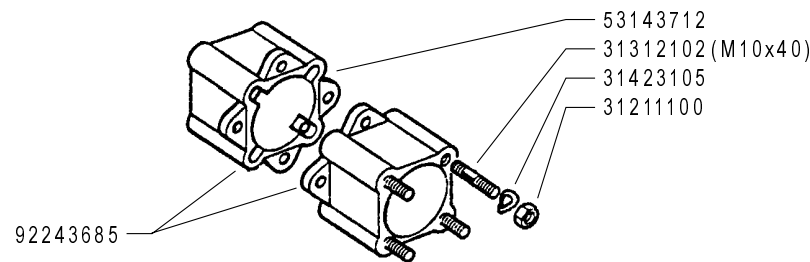
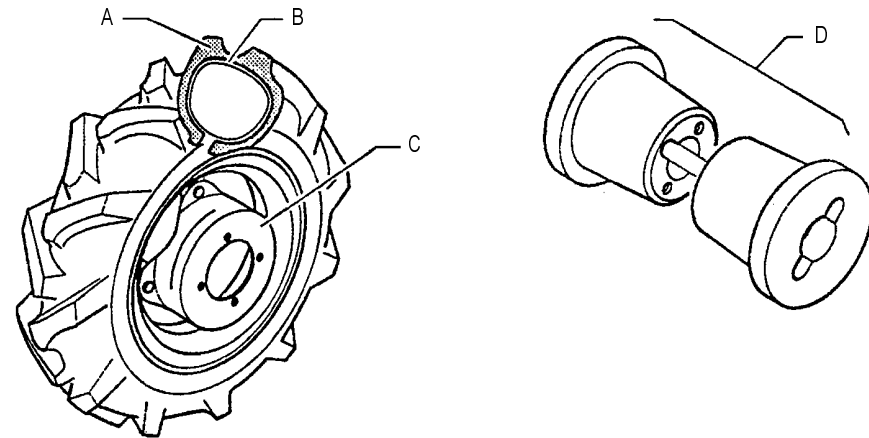

FERRARI

300 TRENDY

RUOTE

WHEELS
RUEDAS

ROUES
RÄDER

DALLA MACCHINA
FROM THE MACHINE
DE LA MACHINE
DE LA MAQUINA
AB DER MASCHINE

★ N.

AGGIORNAMENTO
REVISION
MISE A JOUR
APLAZAMIENTO
ANPASSUNG

K01

Rev. **1**

10/2008

ZENNE

Pos.	Code	Q.ty	Description	Notes
31211100	31211100	1	NUT M10	
31312102	31312102	1	STUD BOLT M10X40X24X12	
31423105	31423105	1	SPRING WASHER 10,5	
39113502	39113502	1	TYRE 3.50-8 2PR	
39114008	39114008	1	TYRE 4.00-8 2PR	
39114010	39114010	1	TYRE 4.0-10 2PR	
39115010	39115010	1	TYRE 5.00-10 2PR	
39115012	39115012	1	TYRE 5.00-12 2PR	
39116018	39116018	1	TYRE 6.5/80-12 2PR	
39413502	39413502	1	INNER TUBE	
39414008	39414008	1	INNER TUBE	
39414010	39414010	1	INNER TUBE	
39415010	39415010	1	INNER TUBE	
39415012	39415012	1	INNER TUBE	
39416018	39416018	1	INNER TUBE	
53143712	53143712	1	SPACER	
58052288	58052288	1	RIM	
58052326	58052326	1	RIM	
58052327	58052327	1	RIM	
58052328	58052328	1	RIM	
92243685	92243685	1	PAIR WHEEL SPACERS 6 CM	
92243686	92243686	1	PAIR OF WEIGHTS FOR 8 WHEELS 11 KGS	
92248715	92248715	1	PAIR OF WEIGHTS FOR 10 WHEELS 15 KGS	
92248720	92248720	1	PAIR OF WEIGHTS FOR 12 AND 15 WHEELS - 34 KGS	
92480721	92480721	1	WEIGHTS KG. 34 FOR WHEELS 5.00-12 / 6.5/80-12 (PAIR) (0901012307)	

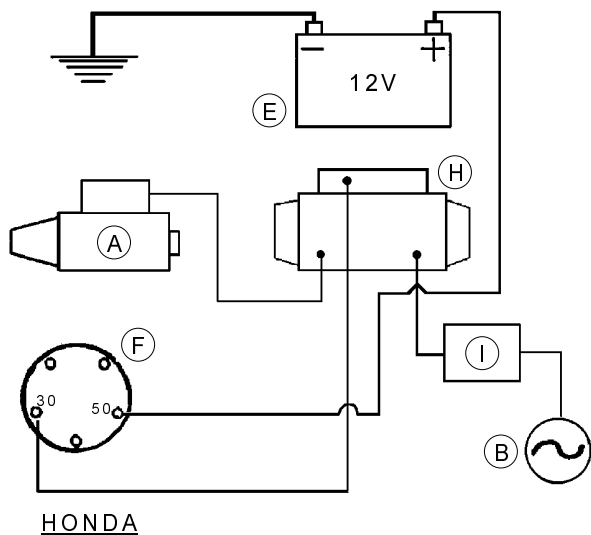

HONDA

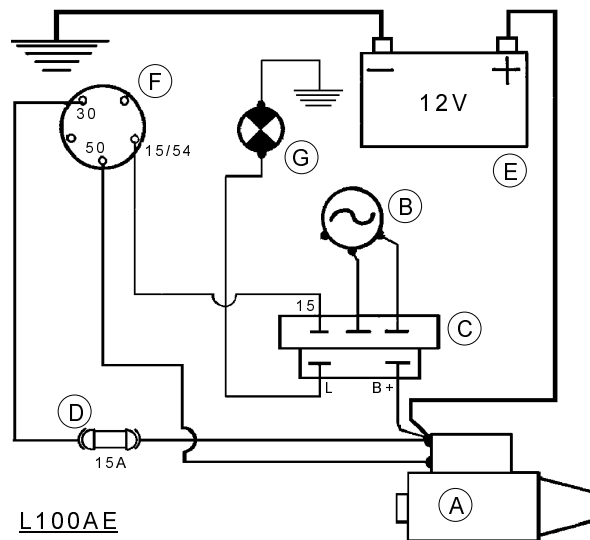

L100AE

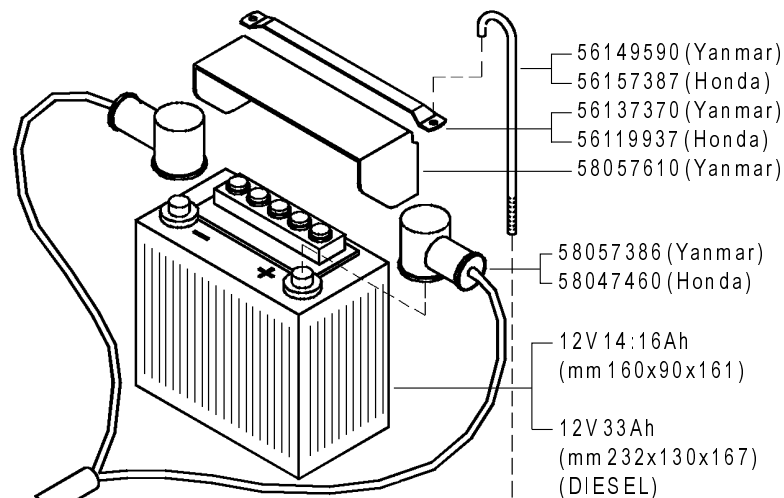

56149590 (Yanmar)
56157387 (Honda)
56137370 (Yanmar)
56119937 (Honda)
58057610 (Yanmar)

58057386 (Yanmar)
58047460 (Honda)

12V 14:16Ah
(mm 160x90x161)

12V 33Ah
(mm 232x130x167)
(DIESEL)

(Yanmar) 30000276
58045807

58057611 (Yanmar)
58057397 (Honda)

(Yanmar) 30000277

58045804 (Yanmar)
30000295 (Yanmar)
59057604 (Yanmar)
59057390 (Honda)

31121558
31411064
31241060

31241060 (M6)

A	B	C	D
MOTORINO D'AVVIAMENTO STARTER DÉMARREUR MOT. DE ARRANQUE ANLASSMOTOR	GENERATORE GENERATOR GÉNÉRATEUR GENERADOR GENERATOR	REGOLATORE REGULATOR RÉGULATEUR REGULADOR REGLER	FUSIBILI FUSES FUSIBLES FUSIBLES SCHMELZSICHERUNGEN

E	F	G	H	I
BATTERIA BATTERY BATTERIE BATERIA BATERIE	INTERRUTTORE SWITCH INTERRUPTEUR INTERRUPTOR SCHALTER	SPIA CARICA BATTERIA BATTERY LONG WARN. LIGHT TEMOIN CHARG. BATTERIE LUZ CARGA BATERIA BATTERIELADUNG KTRL. LAMPE	SOLENOIDE SOLENOID SOLÉNOÏDE SOLENOIDE SOLENOID	DIODO DIODE DIODE DIODO DIODE

FERRARI

300 TRENDY

AVVIAMENTO ELETTRICO (320-330)

ELECTRIC STARTER
ARRANQUE ELECTRICO

DÉMARRAGE ÉLECTRIQUE
ELEKTROSTART

DALLA MACCHINA
FROM THE MACHINE
DE LA MACHINE
DE LA MAQUINA
AB DER MASCHINE

N.

L01 0

11/2006

Rev.

ZENNE

Pos.	Code	Q.ty	Description	Notes
30000276	30000276	1	KEY	
30000277	30000277	1	SWITCH	
30000295	30000295	1	LAMP	
31121558	31121558	1	SCREW TTQ M6X16 UNI 5731	
31241060	31241060	1	HEXAGON SELFLOCK NUT M6	
31411064	31411064	1	WASHER 6,4x12,5	
56119937	56119937	1	BATTERY SUPPORT	
56137370	56137370	1	BATTERY BRACKET	
56149590	56149590	1	BATTERY BRACKET	
56157387	56157387	1	ROD	
58045804	58045804	1	WARNING LIGHT	
58045807	58045807	1	LOCK COVER	
58047460	58047460	1	WIRING	
58057386	58057386	1	WIRING	
58057397	58057397	1	KIT	
58057610	58057610	1	BOX	
58057611	58057611	1	KIT	
59057390	59057390	1	BOX	
59057604	59057604	1	BOX	

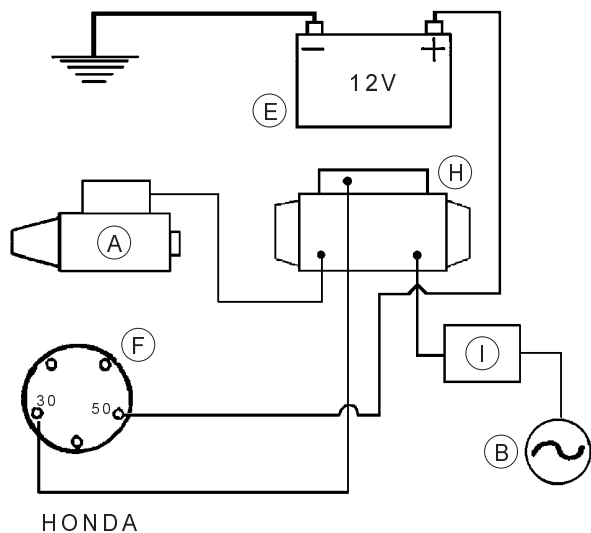

HONDA

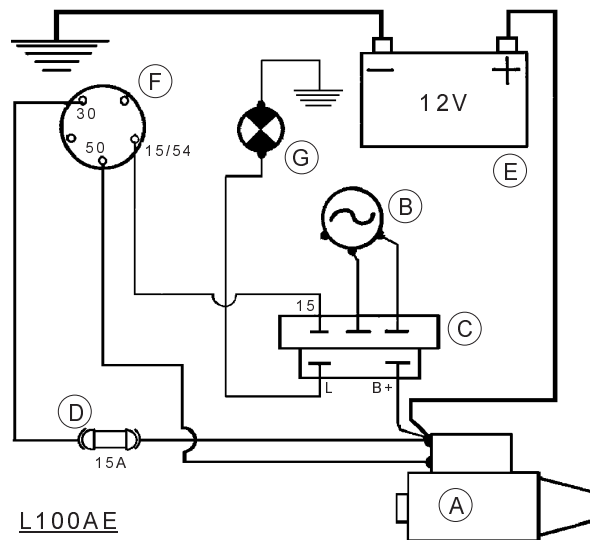

L100AE

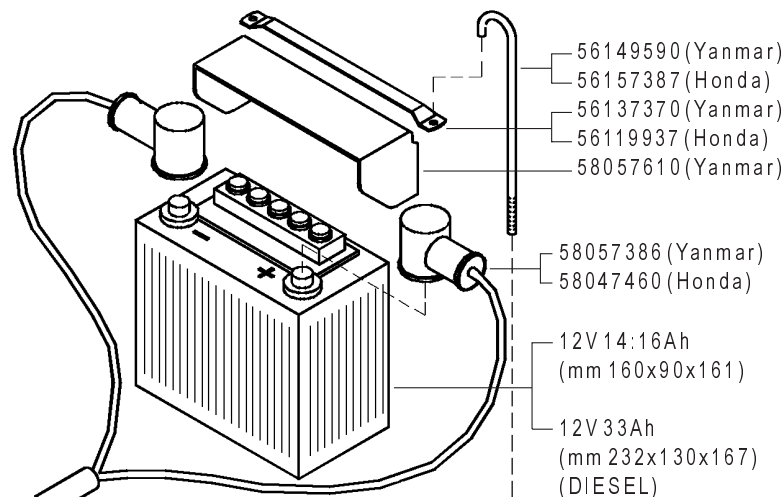

56149590 (Yanmar)
56157387 (Honda)
56137370 (Yanmar)
56119937 (Honda)
58057610 (Yanmar)

58057386 (Yanmar)
58047460 (Honda)

12V 14:16Ah
(mm 160x90x161)

12V 33Ah
(mm 232x130x167)
(DIESEL)

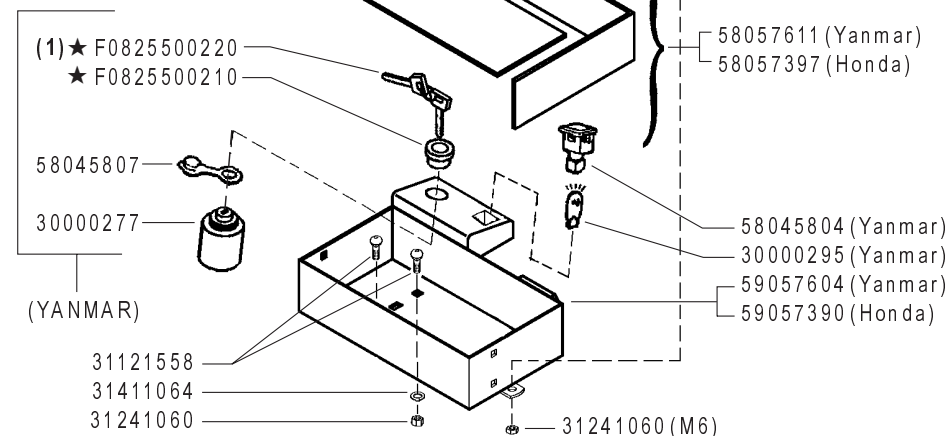

(1) ★ F0825500220
★ F0825500210

58045807

30000277

(YANMAR)

31121558

31411064

31241060

58057611 (Yanmar)
58057397 (Honda)

58045804 (Yanmar)

30000295 (Yanmar)

59057604 (Yanmar)

59057390 (Honda)

AGGIORNAMENTO

REVISION

MISE A JOUR

APLAZAMIENTO

ANPASSUNG

Rev.

L01 1

01/2007

ZENNE

A	B	C	D
MOTORINO D'AVVIAMENTO STARTER DÉMARREUR MOT. DEARRANQUE ANLASSMOTOR	GENERATORE GENERATOR GÉNÉRATEUR GENERADOR GENERATOR	REGOLATORE REGULATOR RÉGULATEUR REGULADOR REGLER	FUSIBILI FUSES FUSIBLES FUSIBLES SCHMELZSICHERUNGEN

E	F	G	H	I
BATTERIA BATTERY BATTERIE BATERIA BATERIE	INTERRUTTORE SWITCH INTERRUPTEUR INTERRUPTOR SCHALTER	SPIACARICABATTERIA BATTERY LONG WARN. LIGHT TEMOIN CHARG. BATTERIE LUZ CARGA BATERIA BATTERIELADUNG KTRL. LAMPE	SOLENOIDE SOLENOID SOLÉNOÏDE SOLENOIDE SOLENOID	DIODO DIODE DIODE DIODE DIODE

(1) sostituisce 30000276

FERRARI

300 TRENDY

AVVIAMENTO ELETTRICO (320 - 330)

ELECTRIC STARTER
ARRANQUE ELECTRICO

DÉMARRAGE ÉLECTRIQUE
ELEKTROSTART

DALLA MACCHINA
FROM THE MACHINE
DE LA MACHINE
DE LA MAQUINA
AB DER MASCHINE

★N.

Pos.	Code	Q.ty	Description	Notes
30000277	30000277	1	SWITCH	
30000295	30000295	1	LAMP	
31121558	31121558	1	SCREW TTQ M6X16 UNI 5731	
31241060	31241060	1	HEXAGON SELFLOCK NUT M6	
31411064	31411064	1	WASHER 6,4x12,5	
56119937	56119937	1	BATTERY SUPPORT	
56137370	56137370	1	BATTERY BRACKET	
56149590	56149590	1	BATTERY BRACKET	
56157387	56157387	1	ROD	
58045804	58045804	1	WARNING LIGHT	
58045807	58045807	1	LOCK COVER	
58047460	58047460	1	WIRING	
58057386	58057386	1	WIRING	
58057397	58057397	1	KIT	
58057610	58057610	1	BOX	
58057611	58057611	1	KIT	
59057390	59057390	1	BOX	
59057604	59057604	1	BOX	
F0825500	F0825500210	1	RING NUT	
F0825500	F0825500220	1	KEY	

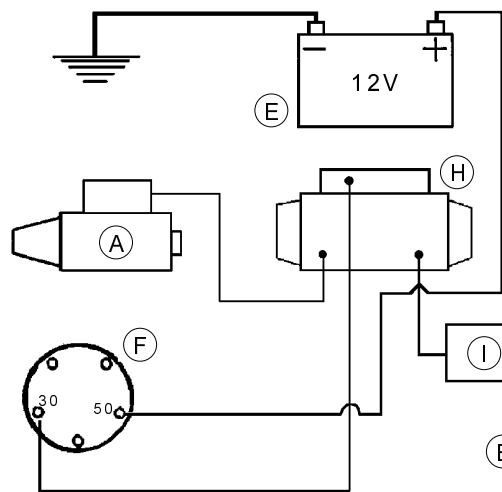

HONDA

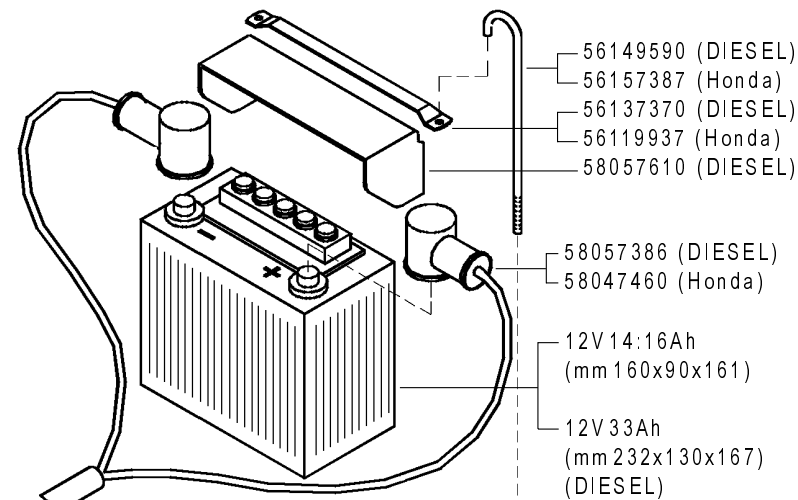
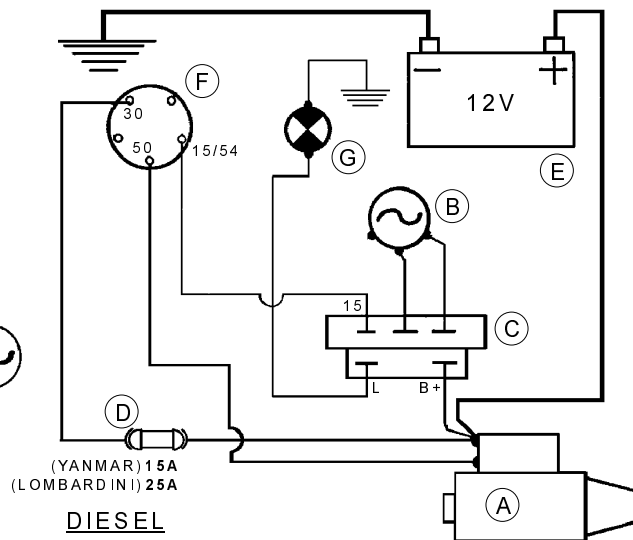

A	B	C	D
MOTORINO D'AVVIAMENTO STARTER DÉMARREUR MOT. DE ARRANQUE ANLASSMOTOR	GENERATORE GENERATOR GÉNÉRATEUR GENERADOR GENERATOR	REGOLATORE REGULATOR RÉGULATEUR REGULADOR REGLER	FUSIBILI FUSES FUSIBLES FUSIBLES SCHMELZSICHERUNGEN

E	F	G	H	I
BATTERIA BATTERY BATERIE BATERIA BATERIE	INTERRUTTORE SWITCH INTERRUPTEUR INTERRUPTOR SCHALTER	SPIA CARICA BATTERIA BATTERY LONG WARN. LIGHT TEMOIN CHARG. BATTERIE LUZ CARGA BATERIA BATERIE LADUNG KTRL. LAMPE	SOLENOIDE SOLENOID SOLÉNOÏDE SOLENOIDE SOLENOID	DIODO DIODE DIODE DIODE DIODE

(1) sostituisce 30000276

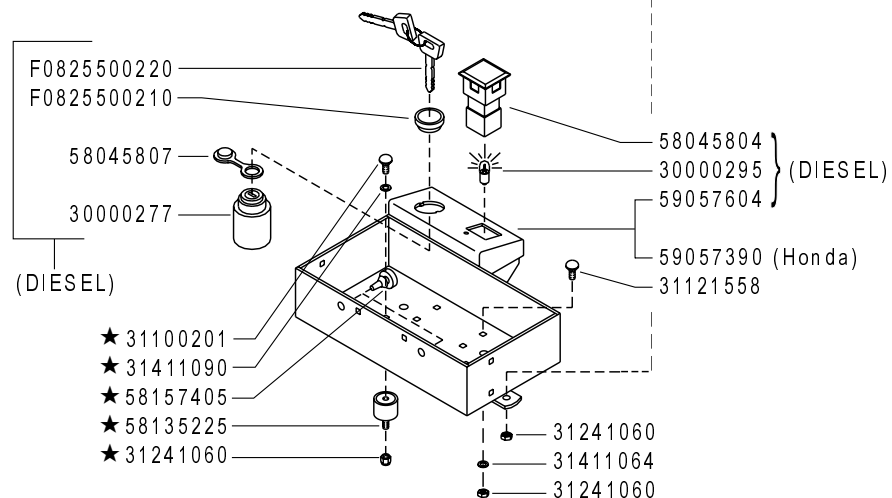

FERRARI

300 TRENDY

AVVIAMENTO ELETTRICO (320 - 330 - 340 ★)

ELECTRIC STARTER
ARRANQUE ELECTRICO

DÉMARRAGE ÉLECTRIQUE
ELEKTROSTART

DALLA MACCHINA
FROM THE MACHINE
DE LA MACHINE
DE LA MAQUINA
AB DER MASCHINE

★ N.

(320) 823723

(330) 823957

L01 2

10/2008

Rev.

ZENNE

Pos.	Code	Q.ty	Description	Notes
30000277	30000277	1	SWITCH	
30000295	30000295	1	LAMP	
31100201	31100201	1	SCREW TTQ M6X12 UNI 5731	
31121558	31121558	1	SCREW TTQ M6X16 UNI 5731	
31241060	31241060	1	HEXAGON SELFLOCK NUT M6	
31411064	31411064	1	WASHER 6,4x12,5	
31411090	31411090	1	WASHER 9x24	
56119937	56119937	1	BATTERY SUPPORT	
56137370	56137370	1	BATTERY BRACKET	
56149590	56149590	1	BATTERY BRACKET	
56157387	56157387	1	ROD	
58045804	58045804	1	WARNING LIGHT	
58045807	58045807	1	LOCK COVER	
58047460	58047460	1	WIRING	
58057386	58057386	1	WIRING	
58057610	58057610	1	BOX	
58135225	58135225	1	VIBRATION-DAMPING	
58157405	58157405	1	PLUG	
59057390	59057390	1	BOX	
59057604	59057604	1	BOX	
F0825500	F0825500210	1	RING NUT	
F0825500	F0825500220	1	KEY	

SERIAL

ELECTRIC STARTER

Version: 320 trendy, 330 trendy

CODE REV

L01_2_60940



58057767

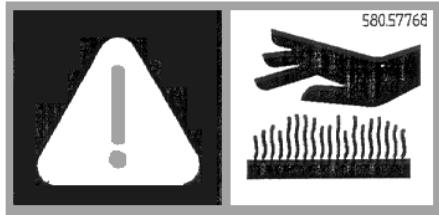

58057768



58046912



58057724

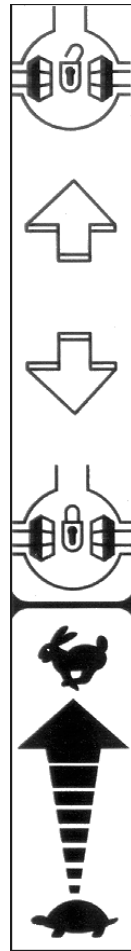

58057688



58057676



58057678

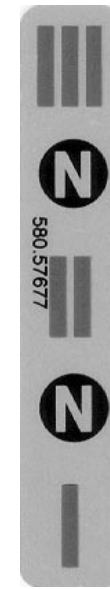

58057677

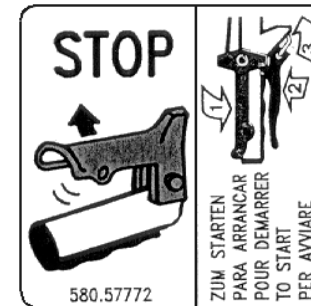

58057772



58057770

FERRARI

300 TRENDY

ADESIVE

STICKERS
ADHESIVOS

AUTOCOLLANTS
AUFKLEBES

DALLA MACCHINA
FROM THE MACHINE
DE LA MACHINE
DE LA MAQUINA
AB DER MASCHINE

N.

Rev. **M01** 0

11/2006

ZENNE

Pos.	Code	Q.ty	Description	Notes
58046912	58046912	1	DECAL	
58057676	58057676	1	DECAL	
58057677	58057677	1	DECAL	
58057678	58057678	1	DECAL	
58057688	58057688	1	DECAL	
58057724	58057724	1	DECAL	
58057767	58057767	1	DECAL	
58057768	58057768	1	DECAL	
58057770	58057770	1	DECAL	
58057772	58057772	1	DECAL	



58057767

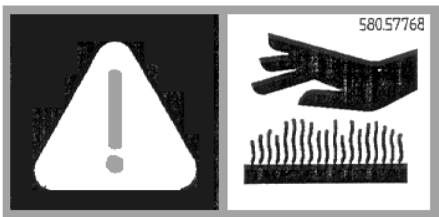

58057768



58057724

580.57770 KUPPLUNG
EMBRAYAGE
EMBRAGUE
CLUTCH
FRIZIONE

58057770

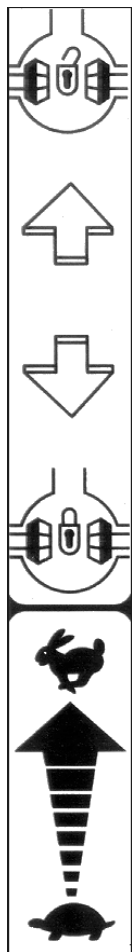

58057688



58057746 ★

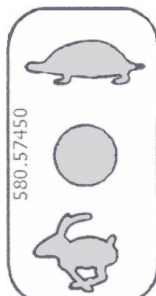

58057450 ★

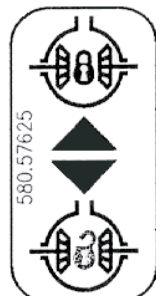

58057625 ★

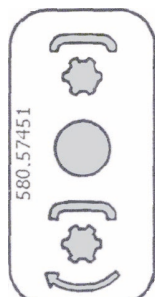

58057451 ★

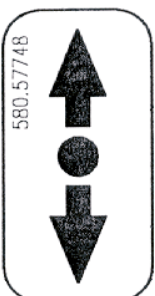

58057748 ★



58093089 ★

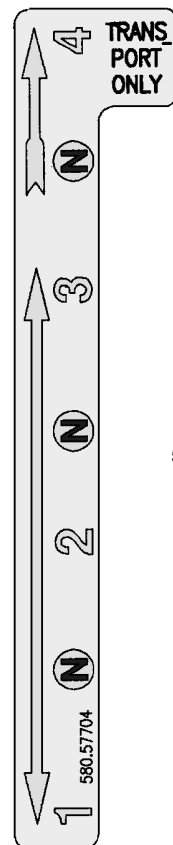

58057704 ★



58057676



58057678

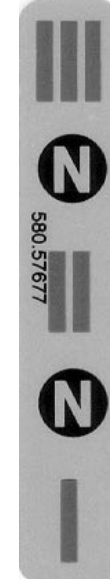

58057677

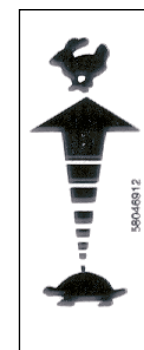

58046912



58057772

FERRARI

300 TRENDY

ADESIVE

STICKERS
ADHESIVOS

AUTOCOLLANTS
AUFKLEBES

DALLA MACCHINA
FROM THE MACHINE
DE LA MACHINE
DE LA MAQUINA
AB DER MASCHINE

★ N.

AGGIORNAMENTO
REVISION
MISE A JOUR
APLAZAMIENTO
ANPASSUNG

M01 1

10/2008

Rev.

ZENNE

Pos.	Code	Q.ty	Description	Notes
58046912	58046912	1	DECAL	
58057450	58057450	1	DECAL	
58057451	58057451	1	DECAL	
58057625	58057625	1	DECAL	
58057676	58057676	1	DECAL	
58057677	58057677	1	DECAL	
58057678	58057678	1	DECAL	
58057688	58057688	1	DECAL	
58057704	58057704	1	DECAL	
58057724	58057724	1	DECAL	
58057746	58057746	1	DECAL	
58057748	58057748	1	DECAL	
58057767	58057767	1	DECAL	
58057768	58057768	1	DECAL	
58057770	58057770	1	DECAL	
58057772	58057772	1	DECAL	
58093089	58093089	1	DECAL	

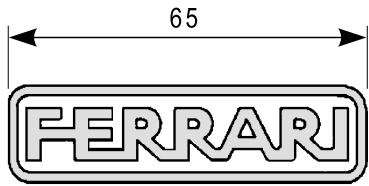

58052156



58052037



58052026



58052039

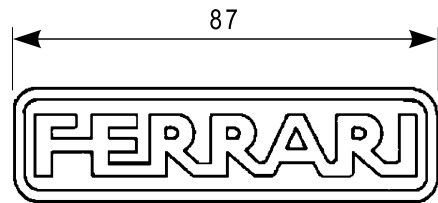

58052019

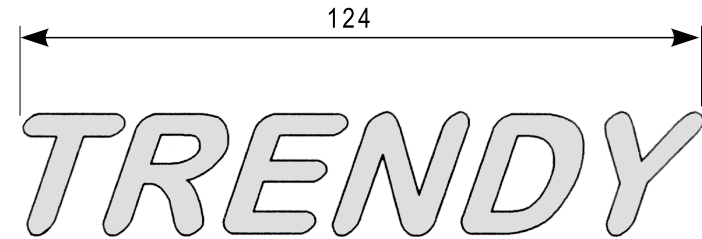

58052045

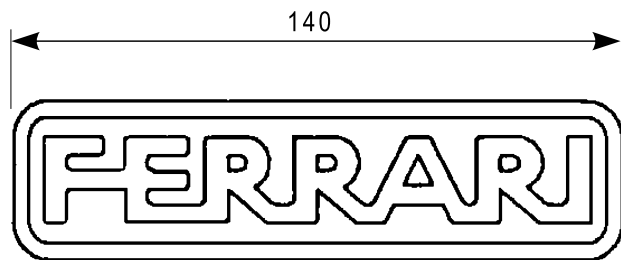

58052029

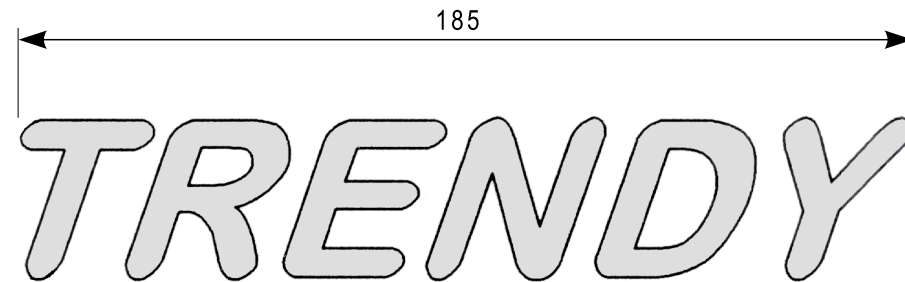

58052046

FERRARI

300 TRENDY

ADESIVI

STICKERS
ADHESIVOS

AUTOCOLLANTS
AUFKLEBES

DALLA MACCHINA
FROM THE MACHINE
DE LA MACHINE
DE LA MAQUINA
AB DER MASCHINE

N.

M02 0

11/2006

Rev.

ZENNE

Pos.	Code	Q.ty	Description	Notes
58052019	58052019	1	DECAL	
58052026	58052026	1	DECAL	
58052029	58052029	1	DECAL	
58052037	58052037	1	DECAL	
58052039	58052039	1	DECAL	
58052045	58052045	1	DECAL	
58052046	58052046	1	DECAL	
58052156	58052156	1	DECAL	

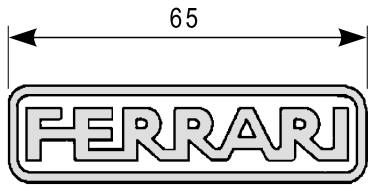

58052156

310

58052037

320

58052026

330

58052039

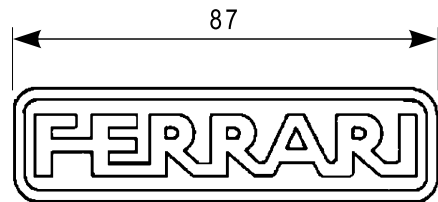

58052019

340

58052047 ★

TRENDY

58052045

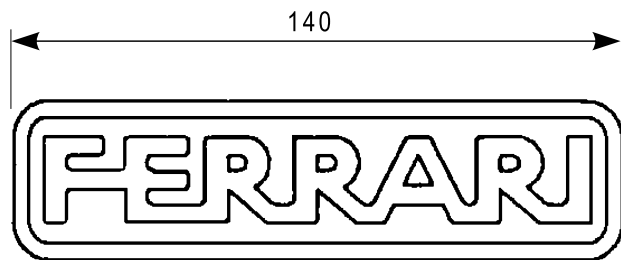

58052029

TRENDY

58052046

FERRARI

300 TRENDY

STICKERS
ADHESIVOS

ADESIVI

AUTOCOLLANTS
AUFKLEBES

DALLA MACCHINA
FROM THE MACHINE
DE LA MACHINE
DE LA MAQUINA
AB DER MASCHINE

AGGIORNAMENTO

REVISION

MISE A JOUR

APLAZAMIENTO

ANPASSUNG

★ N.

M02 1

10/2008

Rev.

ZENNE

Pos.	Code	Q.ty	Description	Notes
58052019	58052019	1	DECAL	
58052026	58052026	1	DECAL	
58052029	58052029	1	DECAL	
58052037	58052037	1	DECAL	
58052039	58052039	1	DECAL	
58052045	58052045	1	DECAL	
58052046	58052046	1	DECAL	
58052047	58052047	1	DECAL	
58052156	58052156	1	DECAL	

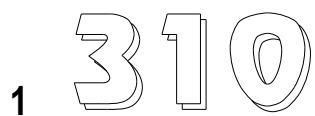

i = info - stop 2 sec. ★ = new part

Pos.	Code	Q.ty	Description	Notes
1	58052178		DECAL	
2	58052179		DECAL	
3	58052180		DECAL	
4	58052181		DECAL	
5	58052019		DECAL	
6	58052029		DECAL	
7	58052045		DECAL	
8	58052046		DECAL	

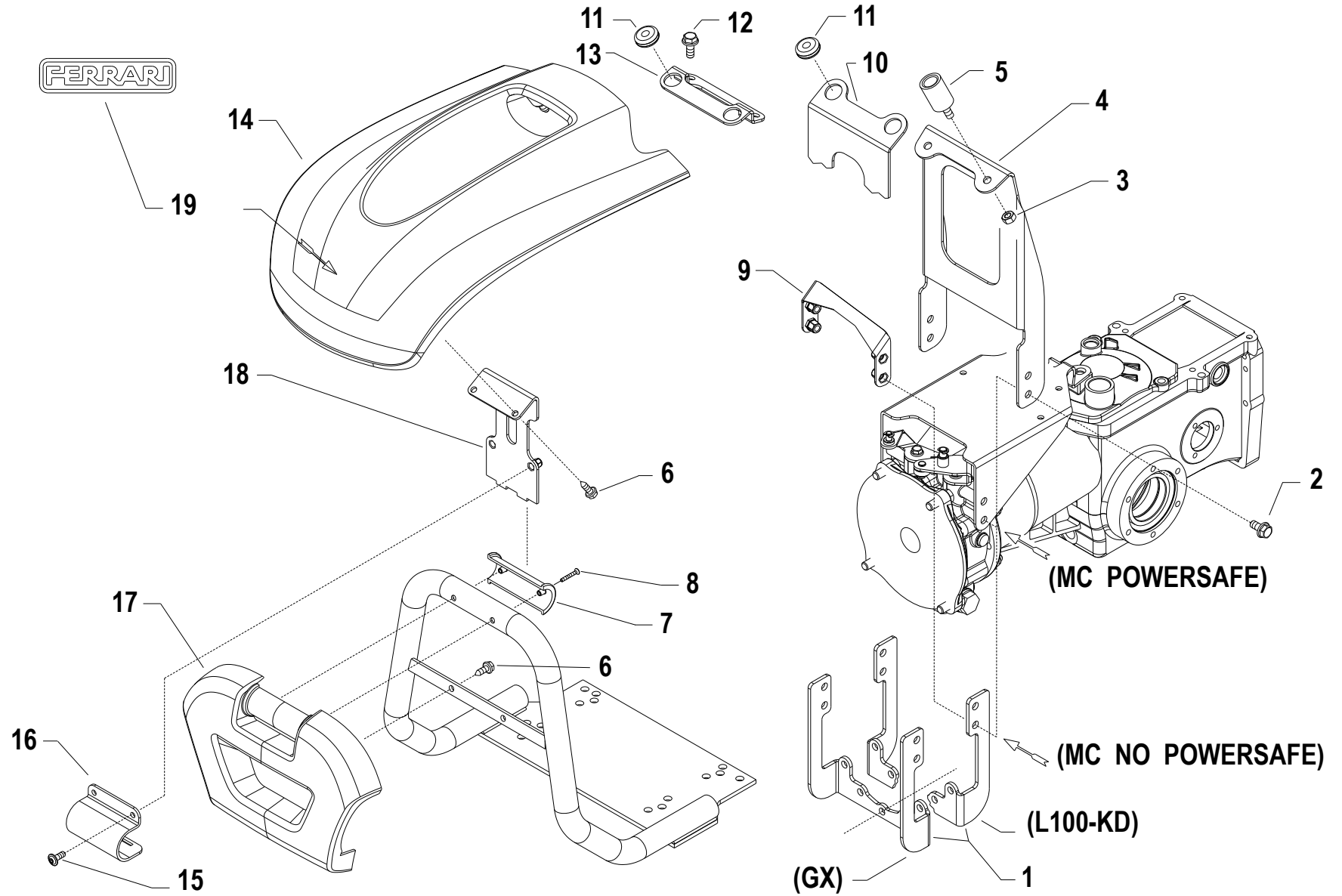

i = info - stop 2 sec. ★ = new part

Pos.	Code	Q.ty	Description	Notes
1	56157515N		HOLDER	
2	31112170		SCREW TE C/F M8X20 DIN 6921	
3	31211080		NUT M8	
4	56157516N		SUPPORT	L100
4	56157498N		SUPPORT	KD440
4	56157499N		SUPPORT	KD350 - GX340 - GX390 - POWERSAFE
4	56157513N		SUPPORT	GX270
5	58042111		STOPPER	
6	31510100		RIBBED SCREW 6,3X19 UNI 6950	
7	55252504		HALF BEARING	
8	31100451		SCREW 3,5X25	
9	59257488		SUPPORT	NO POWERSAFE SERIES
10	56157495N		SUPPORT	KD350
11	58056991		CABLE GLAND	
12	31112171		SCREW TE C/F M8X16 DIN 6921	3LD510
13	561C0078N		REAR SUPPORT	3LD510
14	55252502		BONNET	
15	31121018		SCREW TBCEI FLANG. M6X16	
16	56157519N		RH HINGE	
17	55252503		FREGIO ANT.MC 2010 FERRARI	
18	59257517		PLATE	KD440 - L100
18	59257523		PLATE	KD350 - GX
18	592C0080		PLATE	3LD510
19	53052175		MEDIUM FERRARI BRAND	

SPARE PARTS INSTANCE INDEX





SPARE PARTS INSTANCE INDEX

Code	Parts Table	Pos.	Q.ty	Code	Parts Table	Pos.	Q.ty	Code	Parts Table	Pos.	Q.ty	
30000276	L01_0_27535	30000276	1	31111097	I02_1_45506	31111097	1	31112170	S.01.01.A0027_00	2		
30000277	L01_0_27535	30000277	1	31111217	J.02.01.A0027_01	21		31112171	S.01.01.A0027_00	12		
	L01_1_33613	30000277	1		J02_0_27474	31111217	1	31112211	F.02.02.A0027_01	24		
	L01_2_60940	30000277	1	31111229	H.02.01.A0027_02	1			F02_0_27212	31112211	1	
30000295	L01_0_27535	30000295	1		H.02.01.A0027_03	1		31112293	H.02.01.A0027_02	18		
	L01_1_33613	30000295	1		H02_0_27310	31111229	1			H.02.01.A0027_03	20	
	L01_2_60940	30000295	1		H02_1_60701	31111229	1			H02_0_27310	31112293	1
30010142	J.02.01.A0027_01	20		31112081	C.01.01.A0027_04	7			H02_1_60701	31112293	1	
	J02_0_27474	30010142	1	31112083	E.01.01.A0027_01	1		31121018	S.01.01.A0027_00	15		
30040001	E.01.01.A0027_01	9		31112085	C01_3_60548	31112085	1	31121020	I.02.01.A0027_02	27		
	E01_0_27146	30040001	1	31112089	I.02.01.A0027_02	5			J.04.01.A0027_00	18		
30040133	E01_0_27146	30040133	1		I02_0_27387	31112089	1	31121024	H.02.01.A0027_02	21		
31100003	D.01.02.A0027_03	13			I02_1_45506	31112089	1		H.02.01.A0027_03	23		
	D01_0_27123	31100003	1	31112090	J.04.01.A0027_00	1		31121558	C01_0_27103	31121558	1	
	D01_1_33518	31100003	1	31112092	I.02.01.A0027_02	17			C01_1_60543	31121558	1	
	D01_2_60564	31100003	1		I02_0_27387	31112092	1		C01_2_60545	31121558	1	
31100015	D.01.02.A0027_03	13			I02_1_45506	31112092	1		L01_0_27535	31121558	1	
	D01_0_27123	31100015	1	31112150	H02_0_27310	31112150	1		L01_1_33613	31121558	1	
	D01_1_33518	31100015	1		H02_1_60701	31112150	1		L01_2_60940	31121558	1	
	D01_2_60564	31100015	1	31112152	J.02.01.A0027_01	24		31132562	E01_0_27146	31132562	1	
31100201	L01_2_60940	31100201	1		J02_0_27474	31112152	1	31152103	E.01.01.A0027_01	19		
31100451	C.01.01.A0027_04	12		31112153	H02_0_27310	31112153	1		E.01.01.A0027_01	24		
	C01_3_60548	31100451	1		H02_1_60701	31112153	1		E01_0_27146	31152103	1	
	H.02.01.A0027_03	11			I02_0_27387	31112153	1	31211080	D01_0_27123	31211080	1	
	J.02.01.A0027_01	8			I02_1_45506	31112153	1		D01_1_33518	31211080	1	
	J.04.01.A0027_00	9		31112154	C.01.01.A0027_04	1			D01_2_60564	31211080	1	
	S.01.01.A0027_00	8			C01_0_27103	31112154	1		H.02.01.A0027_02	26		
31111086	H02_0_27310	31111086	1		C01_1_60543	31112154	1		H.02.01.A0027_03	28		
	H02_1_60701	31111086	1		C01_2_60545	31112154	1		H02_0_27310	31211080	1	
31111090	E01_0_27146	31111090	1		C01_3_60548	31112154	1		H02_1_60701	31211080	1	
31111091	I02_0_27387	31111091	1	31112165	H.02.01.A0027_02	2			I.02.01.A0027_02	13		
	I02_1_45506	31111091	1		H.02.01.A0027_03	2			I02_0_27387	31211080	1	
31111097	I.02.01.A0027_02	9		31112170	H.02.01.A0027_02	29			I02_1_45506	31211080	1	
	I02_0_27387	31111097	1		H.02.01.A0027_03	31			J.04.01.A0027_00	16		

SPARE PARTS INSTANCE INDEX

Code	Parts Table	Pos.	Q.ty	Code	Parts Table	Pos.	Q.ty	Code	Parts Table	Pos.	Q.ty
31211080	S.01.01.A0027_00	3		31241084	C01_2_60545	31241084	1	31312102	K01_1_60913	31312102	1
31211100	G01_0_27251	31211100	1		C01_3_60548	31241084	1	31312124	E.01.01.A0027_01	6	
	K01_0_27513	31211100	1		E.01.01.A0027_01	5			E01_0_27146	31312124	1
	K01_1_60913	31211100	1		J.02.01.A0027_01	16		31312125	E.01.01.A0027_01	6	
31221121	E.01.01.A0027_01	8			J.04.01.A0027_00	8			E01_0_27146	31312125	1
	E01_0_27146	31221121	1	31241085	E01_0_27146	31241085	1	31411043	H02_0_27310	31411043	1
31241060	C01_0_27103	31241060	1		J02_0_27474	31241085	1		H02_1_60701	31411043	1
	C01_1_60543	31241060	1	31241100	H.02.01.A0027_02	9		31411064	C01_0_27103	31411064	1
	C01_2_60545	31241060	1		H.02.01.A0027_03	9			C01_1_60543	31411064	1
	C01_3_60548	31241060	1		H02_0_27310	31241100	1		C01_2_60545	31411064	1
	I.02.01.A0027_02	15			H02_1_60701	31241100	1		C01_3_60548	31411064	1
	I02_0_27387	31241060	1		J.02.01.A0027_01	18			I02_0_27387	31411064	1
	I02_1_45506	31241060	1		J02_0_27474	31241100	1		I02_1_45506	31411064	1
	L01_0_27535	31241060	1	31241120	G01_0_27251	31241120	1		L01_0_27535	31411064	1
	L01_1_33613	31241060	1	31241126	H.02.01.A0027_02	12			L01_1_33613	31411064	1
	L01_2_60940	31241060	1		H.02.01.A0027_03	14			L01_2_60940	31411064	1
31241066	C.01.01.A0027_04	13			H02_0_27310	31241126	1	31411084	C01_0_27103	31411084	1
31241080	C01_0_27103	31241080	1		H02_1_60701	31241126	1		C01_1_60543	31411084	1
	C01_1_60543	31241080	1	31312082	E.01.01.A0027_01	10			I02_0_27387	31411084	1
	D.01.02.A0027_03	9			E01_0_27146	31312082	1		I02_1_45506	31411084	1
	D01_1_33518	31241080	1		J.02.01.A0027_01	14		31411090	L01_2_60940	31411090	1
	D01_2_60564	31241080	1		J02_0_27474	31312082	1	31411104	J.02.01.A0027_01	37	
	E.01.01.A0027_01	22		31312083	D.01.02.A0027_03	11			J02_0_27474	31411104	1
	E01_0_27146	31241080	1		D01_1_33518	31312083	1	31414130	J.02.01.A0027_01	31	
	H.02.01.A0027_02	10			D01_2_60564	31312083	1		J02_0_27474	31414130	1
	H.02.01.A0027_03	10		31312086	E.01.01.A0027_01	11		31421083	E.01.01.A0027_01	21	
	H02_0_27310	31241080	1		E01_0_27146	31312086	1		E01_0_27146	31421083	1
	H02_1_60701	31241080	1	31312088	D01_0_27123	31312088	1		H02_0_27310	31421083	1
	I02_0_27387	31241080	1		D01_1_33518	31312088	1		H02_1_60701	31421083	1
	I02_1_45506	31241080	1		D01_2_60564	31312088	1		J02_0_27474	31421083	1
	J.02.01.A0027_01	1		31312094	E.01.01.A0027_01	3		31421100	H02_0_27310	31421100	1
	J02_0_27474	31241080	1		E01_0_27146	31312094	1		H02_1_60701	31421100	1
31241083	D.01.02.A0027_03	9		31312102	G01_0_27251	31312102	1	31421100Z	H.02.01.A0027_02	13	
31241084	C.01.01.A0027_04	2			K01_0_27513	31312102	1		H.02.01.A0027_03	15	



SPARE PARTS INSTANCE INDEX

Code	Parts Table	Pos.	Q.ty	Code	Parts Table	Pos.	Q.ty	Code	Parts Table	Pos.	Q.ty
31421101	F.02.02.A0027_01	25		34110028	J02_0_27474	34110028	1	37112173	D01_2_60564	37112173	1
	F02_0_27212	31421101	1	34211042	F.02.02.A0027_01	17		37112229	F.02.02.A0027_01	7	
31421130	G01_0_27251	31421130	1		F02_0_27212	34211042	1		F02_0_27212	37112229	1
31422064	E01_0_27146	31422064	1	34213020	I02_0_27387	34213020	1	37112231	D01_0_27123	37112231	1
31423084	D.01.02.A0027_03	12			I02_1_45506	34213020	1	37112233	D01_0_27123	37112233	1
	D01_0_27123	31423084	1		J.02.01.A0027_01	25		37320120	F.02.02.A0027_01	14	
	D01_1_33518	31423084	1		J02_0_27474	34213020	1		F02_0_27212	37320120	1
	D01_2_60564	31423084	1	34213022	J02_0_27474	34213022	1	37910832	F.02.02.A0027_01	12	
	E01_0_27146	31423084	1	34213024	J.02.01.A0027_01	35			F02_0_27212	37910832	1
	H02_0_27310	31423084	1		J02_0_27474	34213024	1	37911532	J.02.01.A0027_01	13	
	H02_1_60701	31423084	1	34213060	F.02.02.A0027_01	19			J02_0_27474	37911532	1
	I02_0_27387	31423084	1		F02_0_27212	34213060	1	38111191	J.02.01.A0027_01	30	
	I02_1_45506	31423084	1	34213061	F.02.02.A0027_01	21			J02_0_27474	38111191	1
	J.02.01.A0027_01	23			F02_0_27212	34213061	1	38211400	J.02.01.A0027_01	12	
	J02_0_27474	31423084	1	34311060	G01_0_27251	34311060	1		J02_0_27474	38211400	1
31423105	D.01.02.A0027_03	12		35111052	F.02.02.A0027_01	30		38211500	F.02.02.A0027_01	23	
	D01_0_27123	31423105	1		F02_0_27212	35111052	1		F02_0_27212	38211500	1
	D01_1_33518	31423105	1		G01_0_27251	35111052	1	38212501	G01_0_27251	38212501	1
	D01_2_60564	31423105	1	35111055	F.02.02.A0027_01	8		38213800	F.02.02.A0027_01	9	
	G01_0_27251	31423105	1		F02_0_27212	35111055	1		F02_0_27212	38213800	1
	K01_0_27513	31423105	1	35121031	F.02.02.A0027_01	6		39113502	K01_0_27513	39113502	1
	K01_1_60913	31423105	1		F02_0_27212	35121031	1		K01_1_60913	39113502	1
31423130	E.01.01.A0027_01	7		35211120	F.02.02.A0027_01	31		39114008	K01_0_27513	39114008	1
	E01_0_27146	31423130	1		F02_0_27212	35211120	1		K01_1_60913	39114008	1
31510099	C01_0_27103	31510099	1	37111150	F.02.02.A0027_01	1		39114010	K01_0_27513	39114010	1
	C01_1_60543	31510099	1		F02_0_27212	37111150	1		K01_1_60913	39114010	1
	C01_2_60545	31510099	1	37111152	F.02.02.A0027_01	34		39115010	K01_0_27513	39115010	1
31510100	C.01.01.A0027_04	10			F02_0_27212	37111152	1		K01_1_60913	39115010	1
	C01_0_27103	31510100	1	37111250	F02_0_27212	37111250	1	39115012	K01_0_27513	39115012	1
	C01_1_60543	31510100	1		G01_0_27251	37111250	1		K01_1_60913	39115012	1
	C01_2_60545	31510100	1	37111255	F.02.02.A0027_01	28		39116018	K01_1_60913	39116018	1
	C01_3_60548	31510100	1	37112173	D.01.02.A0027_03	6		39413502	K01_0_27513	39413502	1
	S.01.01.A0027_00	6			D01_0_27123	37112173	1		K01_1_60913	39413502	1
34110028	J.02.01.A0027_01	15			D01_1_33518	37112173	1	39414008	K01_0_27513	39414008	1



SPARE PARTS INSTANCE INDEX

Code	Parts Table	Pos.	Q.ty	Code	Parts Table	Pos.	Q.ty	Code	Parts Table	Pos.	Q.ty
39414008	K01_1_60913	39414008	1	52456370	F.02.02.A0027_01	3		55102714	H02_1_60701	55102714	1
39414010	K01_0_27513	39414010	1		F02_0_27212	52456370	1	55142076	J02_0_27474	55142076	1
	K01_1_60913	39414010	1	52456389	F.02.02.A0027_01	20		55147842	D01_1_33518	55147842	1
39415010	K01_0_27513	39415010	1		F02_0_27212	52456389	1		D01_2_60564	55147842	1
	K01_1_60913	39415010	1	52456390	F.02.02.A0027_01	22		55156481	D.01.02.A0027_03	2	
39415012	K01_0_27513	39415012	1		F02_0_27212	52456390	1	55157212	H.02.01.A0027_03	13	
	K01_1_60913	39415012	1	52456706	F.02.02.A0027_01	5			J.02.01.A0027_01	6	
39416018	K01_1_60913	39416018	1	53052175	S.01.01.A0027_00	19			J.04.01.A0027_00	7	
50956262	D.01.02.A0027_03	4		53143128V	E.01.01.A0027_01	17		55157213	H.02.01.A0027_03	12	
	D01_0_27123	50956262	1	53143712	K01_0_27513	53143712	1		J.02.01.A0027_01	7	
	D01_1_33518	50956262	1		K01_1_60913	53143712	1		J.04.01.A0027_00	10	
	D01_2_60564	50956262	1	53143875V	E.01.01.A0027_01	17		55157214	J.04.01.A0027_00	23	
52156810Z	J.04.01.A0027_00	21		53152401	E01_0_27146	53152401	1	55157215	J.04.01.A0027_00	22	
52156917	H.02.01.A0027_02	14		53152408	E01_0_27146	53152408	1	55157609	D.01.02.A0027_03	1	
	H.02.01.A0027_03	16		53152409	E01_0_27146	53152409	1		D01_0_27123	55157609	1
	H02_0_27310	52156917	1	53152410	E01_0_27146	53152410	1		D01_1_33518	55157609	1
	H02_1_60701	52156917	1	53152412	E01_0_27146	53152412	1		D01_2_60564	55157609	1
52357250	J.02.01.A0027_01	29		53156150	D.01.02.A0027_03	10		55242528	J.02.01.A0027_01	4	
	J02_0_27474	52357250	1		D01_0_27123	53156150	1	55243340	H.02.01.A0027_02	3	
52447896	D.01.02.A0027_03	3			D01_1_33518	53156150	1		H.02.01.A0027_03	3	
	D01_0_27123	52447896	1		D01_2_60564	53156150	1		H02_0_27310	55243340	1
	D01_1_33518	52447896	1	53156332V	E.01.01.A0027_01	4			H02_1_60701	55243340	1
	D01_2_60564	52447896	1	53156346	E01_0_27146	53156346	1	55248038	I.02.01.A0027_02	16	
52456335	F.02.02.A0027_01	10		53156346V	E.01.01.A0027_01	15			I02_0_27387	55248038	1
	F02_0_27212	52456335	1	53156860	J.04.01.A0027_00	6			I02_1_45506	55248038	1
52456339	F.02.02.A0027_01	33		53247488	D.01.02.A0027_03	10		55248041	I.02.01.A0027_02	20	
	F02_0_27212	52456339	1		D01_0_27123	53247488	1		I02_0_27387	55248041	1
52456349	F.02.02.A0027_01	26			D01_1_33518	53247488	1		I02_1_45506	55248041	1
	F02_0_27212	52456349	1		D01_2_60564	53247488	1	55248283	I02_0_27387	55248283	1
52456354	F.02.02.A0027_01	35		54143090	G01_0_27251	54143090	1		I02_1_45506	55248283	1
	F02_0_27212	52456354	1	55102678	E.01.01.A0027_01	13		55248284	I02_0_27387	55248284	1
52456361	F.02.02.A0027_01	32			E01_0_27146	55102678	1		I02_1_45506	55248284	1
	F02_0_27212	52456361	1	55102714	H.02.01.A0027_02	11		55248379	J.02.01.A0027_01	36	
52456362	F02_0_27212	52456362	1		H02_0_27310	55102714	1		J02_0_27474	55248379	1



SPARE PARTS INSTANCE INDEX

Code	Parts Table	Pos.	Q.ty	Code	Parts Table	Pos.	Q.ty	Code	Parts Table	Pos.	Q.ty
55249668	H02_0_27310	55249668	1	56119937	L01_0_27535	56119937	1	56156276	D.01.02.A0027_03	8	
	H02_1_60701	55249668	1		L01_1_33613	56119937	1		D01_0_27123	56156276	1
55252405	C.01.01.A0027_04	16			L01_2_60940	56119937	1		D01_1_33518	56156276	1
	C01_0_27103	55252405	1	56137370	L01_0_27535	56137370	1		D01_2_60564	56156276	1
	C01_1_60543	55252405	1		L01_1_33613	56137370	1	56156281	D.01.02.A0027_03	8	
	C01_2_60545	55252405	1		L01_2_60940	56137370	1		D01_0_27123	56156281	1
	C01_3_60548	55252405	1	56143059	G01_0_27251	56143059	1		D01_1_33518	56156281	1
55252406	C.01.01.A0027_04	15		56147520Z	E.01.01.A0027_01	2			D01_2_60564	56156281	1
	C01_0_27103	55252406	1	56147655	I02_0_27387	56147655	1	56156284	D.01.02.A0027_03	7	
	C01_1_60543	55252406	1		I02_1_45506	56147655	1		D01_1_33518	56156284	1
	C01_2_60545	55252406	1	56147655N	I.02.01.A0027_02	8			D01_2_60564	56156284	1
	C01_3_60548	55252406	1	56147845	D.01.02.A0027_03	5		56156285	D.01.02.A0027_03	7	
55252413	C.01.01.A0027_04	16			D01_1_33518	56147845	1		D01_1_33518	56156285	1
	C01_1_60543	55252413	1		D01_2_60564	56147845	1		D01_2_60564	56156285	1
	C01_2_60545	55252413	1	56147923	E01_0_27146	56147923	1	56156603Z	I.02.01.A0027_02	6	
	C01_3_60548	55252413	1	56147923N	E.01.01.A0027_01	18		56156792Z	J.02.01.A0027_01	5	
55252415	C01_0_27103	55252415	1	56148037	I.02.01.A0027_02	12		56156832Z	J.04.01.A0027_00	4	
	C01_1_60543	55252415	1		I02_0_27387	56148037	1	56156859Z	J.04.01.A0027_00	19	
	C01_2_60545	55252415	1		I02_1_45506	56148037	1	56156874N	I.02.01.A0027_02	22	
55252502	S.01.01.A0027_00	14		56148285	I02_0_27387	56148285	1	56156940	H.02.01.A0027_02	27	
55252503	C.01.01.A0027_04	9			I02_1_45506	56148285	1		H.02.01.A0027_03	29	
	C01_3_60548	55252503	1	56148286	I02_0_27387	56148286	1		H02_0_27310	56156940	1
	S.01.01.A0027_00	17			I02_1_45506	56148286	1		H02_1_60701	56156940	1
55252504	C.01.01.A0027_04	11		56148287	I02_0_27387	56148287	1	56156948	H02_0_27310	56156948	1
	C01_3_60548	55252504	1		I02_1_45506	56148287	1		H02_1_60701	56156948	1
	S.01.01.A0027_00	7			J.04.01.A0027_00	5		56156948N	H.02.01.A0027_02	16	
55256835	J.04.01.A0027_00	14		56148470N	I.02.01.A0027_02	19		56156974N	H.02.01.A0027_03	18	
55256836	J.04.01.A0027_00	13		56149590	L01_0_27535	56149590	1	56157236	J02_0_27474	56157236	1
55257249	J02_0_27474	55257249	1		L01_1_33613	56149590	1	56157248	J02_0_27474	56157248	1
55257313	J.02.01.A0027_01	28			L01_2_60940	56149590	1	56157257	J02_0_27474	56157257	1
	J02_0_27474	55257313	1	56150361	I02_0_27387	56150361	1	56157257Z	J.02.01.A0027_01	11	
55257321	J.02.01.A0027_01	33			I02_1_45506	56150361	1	56157274	J.02.01.A0027_01	22	
	J02_0_27474	55257321	1	56152403	E01_0_27146	56152403	1		J02_0_27474	56157274	1
552C1001	C.01.01.A0027_04	6		56156195H	J.02.01.A0027_01	17		56157311	J02_0_27474	56157311	1



SPARE PARTS INSTANCE INDEX

Code	Parts Table	Pos.	Q.ty	Code	Parts Table	Pos.	Q.ty	Code	Parts Table	Pos.	Q.ty	
56157312	J02_0_27474	56157312	1	561C0078N	S.01.01.A0027_00	13		58042111	S.01.01.A0027_00	5		
56157324	J02_0_27474	56157324	1	561C1002	C.01.01.A0027_04	5		58042167	H.02.01.A0027_02	17		
56157324N	J.02.01.A0027_01	34		56343058	G01_0_27251	56343058	1		H.02.01.A0027_03	19		
56157332	I02_0_27387	56157332	1	56347484	D01_0_27123	56347484	1		H02_0_27310	58042167	1	
	I02_1_45506	56157332	1	56356251	D01_0_27123	56356251	1		H02_1_60701	58042167	1	
56157387	L01_0_27535	56157387	1	56356328	F.02.02.A0027_01	29			I02_0_27387	58042167	1	
	L01_1_33613	56157387	1		F02_0_27212	56356328	1		I02_1_45506	58042167	1	
	L01_2_60940	56157387	1	56356329	F.02.02.A0027_01	29		58042200	I.02.01.A0027_02	1		
56157393	C01_0_27103	56157393	1		F02_0_27212	56356329	1		I02_0_27387	58042200	1	
	C01_1_60543	56157393	1	56356330	F.02.02.A0027_01	29			I02_1_45506	58042200	1	
	C01_2_60545	56157393	1		F02_0_27212	56356330	1		J.04.01.A0027_00	24		
	C01_3_60548	56157393	1	56356331	F.02.02.A0027_01	29		58042202	I02_0_27387	58042202	1	
56157394	C01_3_60548	56157394	1		F02_0_27212	56356331	1		I02_1_45506	58042202	1	
	E01_0_27146	56157394	1	56356348	F.02.02.A0027_01	16		58043053	E.01.01.A0027_01	12		
56157394N	E.01.01.A0027_01	23			F02_0_27212	56356348	1		E01_0_27146	58043053	1	
56157399	C01_0_27103	56157399	1	56356833Z	J.04.01.A0027_00	11		58043086	F.02.02.A0027_01	18		
	C01_1_60543	56157399	1	56356840Z	J.04.01.A0027_00	2			F02_0_27212	58043086	1	
	C01_2_60545	56157399	1	56356858Z	J.04.01.A0027_00	12		58043117	E.01.01.A0027_01	16		
	C01_3_60548	56157399	1	56356924	H.02.01.A0027_02	6			E01_0_27146	58043117	1	
56157411	H02_0_27310	56157411	1		H.02.01.A0027_03	6		58043176	J.02.01.A0027_01	10		
	H02_1_60701	56157411	1		H02_0_27310	56356924	1		J02_0_27474	58043176	1	
56157411Z	H.02.01.A0027_02	24			H02_1_60701	56356924	1		58043219	I02_0_27387	58043219	1
	H.02.01.A0027_03	26		563C1005Z	J.02.01.A0027_01	3			I02_1_45506	58043219	1	
56157412	H.02.01.A0027_02	28		56456347	F.02.02.A0027_01	15		58045804	L01_0_27535	58045804	1	
	H.02.01.A0027_03	30			F02_0_27212	56456347	1		L01_1_33613	58045804	1	
	H02_0_27310	56157412	1	56456351	F02_0_27212	56456351	1		L01_2_60940	58045804	1	
	H02_1_60701	56157412	1	56456475	F.02.02.A0027_01	27		58045807	L01_0_27535	58045807	1	
56157495N	S.01.01.A0027_00	10			F02_0_27212	56456475	1		L01_1_33613	58045807	1	
56157498N	S.01.01.A0027_00	4		56456736	F.02.02.A0027_01	13			L01_2_60940	58045807	1	
56157499N	S.01.01.A0027_00	4		58002429	I02_0_27387	58002429	1		58046912	M01_0_27555	58046912	1
56157513N	S.01.01.A0027_00	4			I02_1_45506	58002429	1		M01_1_60965	58046912	1	
56157515N	S.01.01.A0027_00	1		58002538	I.02.01.A0027_02	21		58047460	L01_0_27535	58047460	1	
56157516N	S.01.01.A0027_00	4			I02_0_27387	58002538	1		L01_1_33613	58047460	1	
56157519N	S.01.01.A0027_00	16			I02_1_45506	58002538	1		L01_2_60940	58047460	1	

SPARE PARTS INSTANCE INDEX

Code	Parts Table	Pos.	Q.ty	Code	Parts Table	Pos.	Q.ty	Code	Parts Table	Pos.	Q.ty
58047712	H.02.01.A0027_02	23		58052029	M02_1_60983	58052029	1	58056391	F.02.02.A0027_01	11	
	H.02.01.A0027_03	25		58052037	M02_0_27566	58052037	1		F02_0_27212	58056391	1
	H02_0_27310	58047712	1		M02_1_60983	58052037	1	58056593	I.02.01.A0027_02	18	
	H02_1_60701	58047712	1	58052039	M02_0_27566	58052039	1		I02_0_27387	58056593	1
58048000	I.02.01.A0027_02	10			M02_1_60983	58052039	1		I02_1_45506	58056593	1
	I02_0_27387	58048000	1	58052045	M.02.02.A0027_02	7		58056595	I.02.01.A0027_02	14	
	I02_1_45506	58048000	1		M02_0_27566	58052045	1		I02_0_27387	58056595	1
58048002	I02_0_27387	58048002	1		M02_1_60983	58052045	1		I02_1_45506	58056595	1
	I02_1_45506	58048002	1	58052046	M.02.02.A0027_02	8			J.04.01.A0027_00	15	
58048009	H.02.01.A0027_02	22			M02_0_27566	58052046	1	58056815	I.02.01.A0027_02	24	
	H.02.01.A0027_03	24			M02_1_60983	58052046	1	58056848	J.04.01.A0027_00	3	
	H02_0_27310	58048009	1	58052047	M02_1_60983	58052047	1	58056918	H02_0_27310	58056918	1
	H02_1_60701	58048009	1	58052156	M02_0_27566	58052156	1		H02_1_60701	58056918	1
58048012	I02_0_27387	58048012	1		M02_1_60983	58052156	1	58056918Z	H.02.01.A0027_02	7	
	I02_1_45506	58048012	1	58052178	M.02.02.A0027_02	1			H.02.01.A0027_03	7	
58048035	C01_0_27103	58048035	1	58052179	M.02.02.A0027_02	2		58056942	H02_0_27310	58056942	1
	C01_1_60543	58048035	1	58052180	M.02.02.A0027_02	3			H02_1_60701	58056942	1
	C01_2_60545	58048035	1	58052181	M.02.02.A0027_02	4		58056942N	H.02.01.A0027_02	8	
	C01_3_60548	58048035	1	58052288	K01_1_60913	58052288	1		H.02.01.A0027_03	8	
58048355	I.02.01.A0027_02	11		58052326	K01_0_27513	58052326	1	58056991	C.01.01.A0027_04	8	
58049501	I02_0_27387	58049501	1		K01_1_60913	58052326	1		C01_0_27103	58056991	1
	I02_1_45506	58049501	1	58052327	K01_0_27513	58052327	1		C01_1_60543	58056991	1
58049830	J.04.01.A0027_00	20			K01_1_60913	58052327	1		C01_2_60545	58056991	1
58050345	I.02.01.A0027_02	7		58052328	K01_0_27513	58052328	1		C01_3_60548	58056991	1
58051670	I.02.01.A0027_02	3			K01_1_60913	58052328	1		H.02.01.A0027_02	19	
	I02_0_27387	58051670	1	58053035	I02_0_27387	58053035	1		H.02.01.A0027_03	21	
	I02_1_45506	58051670	1		I02_1_45506	58053035	1		H02_0_27310	58056991	1
58052019	M.02.02.A0027_02	5		58056154	I.02.01.A0027_02	23			H02_1_60701	58056991	1
	M02_0_27566	58052019	1		I02_0_27387	58056154	1		S.01.01.A0027_00	11	
	M02_1_60983	58052019	1		I02_1_45506	58056154	1	58057232	J02_0_27474	58057232	1
58052026	M02_0_27566	58052026	1	58056155	I.02.01.A0027_02	23		58057232Z	J.02.01.A0027_01	2	
	M02_1_60983	58052026	1		I02_0_27387	58056155	1	58057263	I02_0_27387	58057263	1
58052029	M.02.02.A0027_02	6			I02_1_45506	58056155	1		I02_1_45506	58057263	1
	M02_0_27566	58052029	1	58056193	I.02.01.A0027_02	25		58057273	J.02.01.A0027_01	27	



SPARE PARTS INSTANCE INDEX

Code	Parts Table	Pos.	Q.ty	Code	Parts Table	Pos.	Q.ty	Code	Parts Table	Pos.	Q.ty
58057273	J02_0_27474	58057273	1	58057610	L01_0_27535	58057610	1	58156156	I02_0_27387	58156156	1
58057284	I02_0_27387	58057284	1		L01_1_33613	58057610	1		I02_1_45506	58156156	1
	I02_1_45506	58057284	1		L01_2_60940	58057610	1	58157405	L01_2_60940	58157405	1
58057285	I.02.01.A0027_02	2		58057611	L01_0_27535	58057611	1	581C1004	C.01.01.A0027_04	4	
58057286	I02_0_27387	58057286	1		L01_1_33613	58057611	1	59015425	E.01.01.A0027_01	14	
58057297	I02_1_45506	58057297	1	58057625	M01_1_60965	58057625	1		E01_0_27146	59015425	1
58057329	I02_0_27387	58057329	1	58057676	M01_0_27555	58057676	1	59043063	G01_0_27251	59043063	1
	I02_1_45506	58057329	1		M01_1_60965	58057676	1	59053021	C01_0_27103	59053021	1
58057385	C.01.01.A0027_04	3		58057677	M01_0_27555	58057677	1		C01_1_60543	59053021	1
	C01_0_27103	58057385	1		M01_1_60965	58057677	1	59053021H	C.01.01.A0027_04	14	
	C01_1_60543	58057385	1	58057678	M01_0_27555	58057678	1		C01_2_60545	59053021	1
	C01_2_60545	58057385	1		M01_1_60965	58057678	1		C01_3_60548	59053021	1
	C01_3_60548	58057385	1	58057688	M01_0_27555	58057688	1	59053040	C01_0_27103	59053040	1
58057386	L01_0_27535	58057386	1		M01_1_60965	58057688	1		C01_1_60543	59053040	1
	L01_1_33613	58057386	1	58057704	M01_1_60965	58057704	1	59053040H	C.01.01.A0027_04	14	
	L01_2_60940	58057386	1	58057724	M01_0_27555	58057724	1		C01_2_60545	59053040	1
58057397	L01_0_27535	58057397	1		M01_1_60965	58057724	1		C01_3_60548	59053040	1
	L01_1_33613	58057397	1	58057746	M01_1_60965	58057746	1	59053221	C01_0_27103	59053221	1
58057413	H.02.01.A0027_02	25		58057748	M01_1_60965	58057748	1		C01_1_60543	59053221	1
	H.02.01.A0027_03	27		58057767	M01_0_27555	58057767	1	59056127H	C.01.01.A0027_04	14	
	H02_0_27310	58057413	1		M01_1_60965	58057767	1		C01_2_60545	59056127	1
	H02_1_60701	58057413	1	58057768	M01_0_27555	58057768	1		C01_3_60548	59056127	1
58057416	H.02.01.A0027_02	31			M01_1_60965	58057768	1	59056258	E.01.01.A0027_01	20	
	H.02.01.A0027_03	33		58057770	M01_0_27555	58057770	1		E01_0_27146	59056258	1
	I02_0_27387	58057416	1		M01_1_60965	58057770	1	59056365	F02_0_27212	59056365	1
	I02_1_45506	58057416	1	58057772	M01_0_27555	58057772	1	59056384	F.02.02.A0027_01	2	
58057417	H.02.01.A0027_02	20			M01_1_60965	58057772	1		F02_0_27212	59056384	1
	H.02.01.A0027_03	22		58093089	M01_1_60965	58093089	1	59056707	F.02.02.A0027_01	4	
	H02_0_27310	58057417	1	58135225	L01_2_60940	58135225	1	59056735N	J.02.01.A0027_01	9	
	H02_1_60701	58057417	1	58147704	I02_0_27387	58147704	1	59056920	J.02.01.A0027_01	19	
58057418	I.02.01.A0027_02	11			I02_1_45506	58147704	1		J02_0_27474	59056920	1
58057419	H02_1_60701	58057419	1	58150313	I.02.01.A0027_02	4		59056935	H.02.01.A0027_02	4	
58057450	M01_1_60965	58057450	1		I02_0_27387	58150313	1		H02_0_27310	59056935	1
58057451	M01_1_60965	58057451	1		I02_1_45506	58150313	1		H02_1_60701	59056935	1



SPARE PARTS INSTANCE INDEX

Code	Parts Table	Pos.	Q.ty
59056952	H02_0_27310	59056952	1
	H02_1_60701	59056952	1
59056952N	H.02.01.A0027_02	5	
	H.02.01.A0027_03	5	
59056995	H02_0_27310	59056995	1
	H02_1_60701	59056995	1
59057010N	H.02.01.A0027_03	4	
59057251	J02_0_27474	59057251	1
59057319	J.02.01.A0027_01	26	
	J02_0_27474	59057319	1
59057390	L01_0_27535	59057390	1
	L01_1_33613	59057390	1
	L01_2_60940	59057390	1
59057604	L01_0_27535	59057604	1
	L01_1_33613	59057604	1
	L01_2_60940	59057604	1
59247489	D.01.02.A0027_03	14	
59247513	D.01.02.A0027_03	14	
59247823	D.01.02.A0027_03	14	
59247884	D01_0_27123	59247884	1
	D01_1_33518	59247884	1
	D01_2_60564	59247884	1
59247924	D01_1_33518	59247924	1
	D01_2_60564	59247924	1
59247971	D01_1_33518	59247971	1
	D01_2_60564	59247971	1
59256255	D.01.02.A0027_03	14	
	D01_1_33518	59256255	1
	D01_2_60564	59256255	1
59256275	D01_0_27123	59256275	1
	D01_1_33518	59256275	1
	D01_2_60564	59256275	1
59256279	D01_0_27123	59256279	1
	D01_1_33518	59256279	1

Code	Parts Table	Pos.	Q.ty
59256279	D01_2_60564	59256279	1
59256280	D01_0_27123	59256280	1
	D01_1_33518	59256280	1
	D01_2_60564	59256280	1
59256850	J.04.01.A0027_00	17	
59256999	H.02.01.A0027_02	15	
	H.02.01.A0027_03	17	
59257151	I02_0_27387	59257151	1
	I02_1_45506	59257151	1
59257162	I.02.01.A0027_02	26	
59257409	H.02.01.A0027_02	30	
	H.02.01.A0027_03	32	
	H02_0_27310	59257409	1
	H02_1_60701	59257409	1
59257488	S.01.01.A0027_00	9	
59257517	S.01.01.A0027_00	18	
59257523	S.01.01.A0027_00	18	
592C0080	S.01.01.A0027_00	18	
592C1010	D.01.02.A0027_03	14	
592C1011	D.01.02.A0027_03	14	
592C1012	D.01.02.A0027_03	14	
92243685	K01_0_27513	92243685	1
	K01_1_60913	92243685	1
92243686	K01_0_27513	92243686	1
	K01_1_60913	92243686	1
92248715	K01_0_27513	92248715	1
	K01_1_60913	92248715	1
92248720	K01_0_27513	92248720	1
	K01_1_60913	92248720	1
92480721	K01_1_60913	92480721	1
F0825500210	L01_1_33613	F0825500	1
	L01_2_60940	F0825500	1
F0825500220	L01_1_33613	F0825500	1
	L01_2_60940	F0825500	1

Code	Parts Table	Pos.	Q.ty
F0831193010	J.02.01.A0027_01	32	
	J02_0_27474	F0831193	1